

## Chapter -13

## Tolerance

**IMPORTANCE :-** Similar to conventional machines such as boring, milling machines, which are manufactures most precisely and used for precision work. Most of the hydraulic presses also required similar precision in manufacturing. e.g. Plastic Injection moulding machine, Powder compacting machine etc. And some components such as cylinders, guides, hydraulic valves etc. are if not made as per standard tolerance then even if press made for common operation such as crushing of scrap etc. will also not work.

Hence understanding the standard of tolerance for various component of a hydraulic press is very important.

## Commonly used fits (IS-2709-1964)

Class of shaft	Class of hole					Recommended surface Roughness Ra $\mu\text{m}$	Type of fits	Application
	H <sub>6</sub>	H <sub>7</sub>	H <sub>8</sub>	H <sub>9</sub>	H <sub>11</sub>			
d	--	d <sub>8</sub>	d <sub>8-10</sub>	--	d <sub>11</sub>	1.6 $\sqrt{\quad}$	Loose running fits	Hydraulic press components, which do not directly affect the accuracy of presses are made in this tolerance grade. e.g. Cam and cam rod of electrical limit switch. Anti-rotation guide rod of Ram, loose pulley etc.
e	e <sub>8</sub>	e <sub>9</sub>	e <sub>8,e9</sub>	--	--	1.6 $\sqrt{\quad}$	Easy running fits	This range of fits are used where as appreciable clearance is permissible, for example press-body and round column assembly, press body and cylinder shell/flange assembly etc.
f	f <sub>6</sub>	f <sub>7</sub>	f <sub>8</sub>	f <sub>8</sub>	--	0.8 $\sqrt{\quad}$ to 0.4 $\sqrt{\quad}$	Normal fits	In this tolerance range the hydraulic cylinder is made. Also all precision component such as gun-metal bushes and round column, die and punch fixing etc. Are made in this tolerance range.
g	g <sub>5</sub>	g <sub>6</sub>	g <sub>7</sub>			0.8 $\sqrt{\quad}$ to 0.4 $\sqrt{\quad}$	Close running fits	This is too close tolerance range. Hydraulic valves are made in H <sub>6</sub> h <sub>5</sub> range, where clearance should not be more than few micron, and oil under pressure has to be seal without elastomeric seal and only with metal to metal contact.
h	h <sub>5</sub>	h <sub>6</sub>	h <sub>7-8</sub>	h <sub>9</sub>	h <sub>11</sub>	0.4 $\sqrt{\quad}$ to 0.2 $\sqrt{\quad}$	Precision sliding fits	
J	j <sub>5</sub>	j <sub>6</sub>	j <sub>7</sub>	--		0.4 $\sqrt{\quad}$ to 0.2 $\sqrt{\quad}$	Push fit	This type of fit is used for accurate location with relatively non-moving part with easy assembly and dismantling for example coupling on motor and pump shaft etc.
k	k <sub>5</sub>	k <sub>6</sub>	k <sub>7</sub>	--		0.4 $\sqrt{\quad}$ to 0.2 $\sqrt{\quad}$	Transition fit	This type of fit is used for light press fit component. Such as phos-phose bronze bush fitting in its housing.

**EXAMPLE :- (Related to hydraulic Press)**

**H<sub>7</sub>k<sub>6</sub>** = This fit is used for fitting phos phose bronze bush in bearing housing.

**H<sub>6</sub> / h<sub>5</sub>** = This fit is used for direction control valve body and spool assembly and similar precision assembly.

**H<sub>7</sub>k<sub>6</sub>** = This fit is used for fixing guide housing and moving platen of press.

**H<sub>9</sub>f<sub>8</sub> / H<sub>9</sub>f<sub>9</sub>** = These fits are used for cylinder and piston, piston rod and guide-bush assembly.

**H<sub>8</sub> / g<sub>8</sub>** = This fit is used between bearing metal bush and round ground and plated column of press.

**H<sub>9</sub>e<sub>8</sub>** = This fit is used for assembly of round column and Bore in press-body.

**H<sub>9</sub>** = This fit is used for cylinder bore, or groove in cylinder.

**h<sub>9</sub>** = This fit is used for Groove on Piston.

**f<sub>9</sub>** = This fit is used for Piston-rod ( Commonly used in hydraulic cylinder)

**h<sub>11</sub>** = This fit is used for piston-rod of high pressure and high precision cylinder.

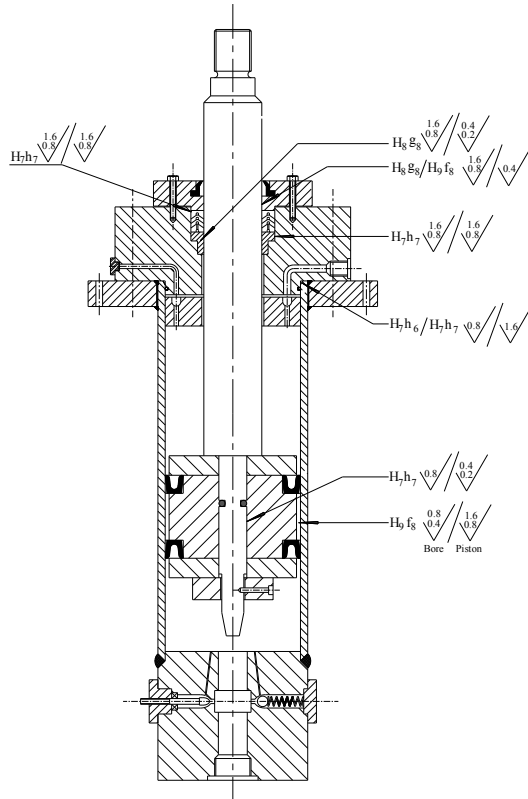

Double Action Front Flange Mounted Cylinder  
Figure No. 13.1

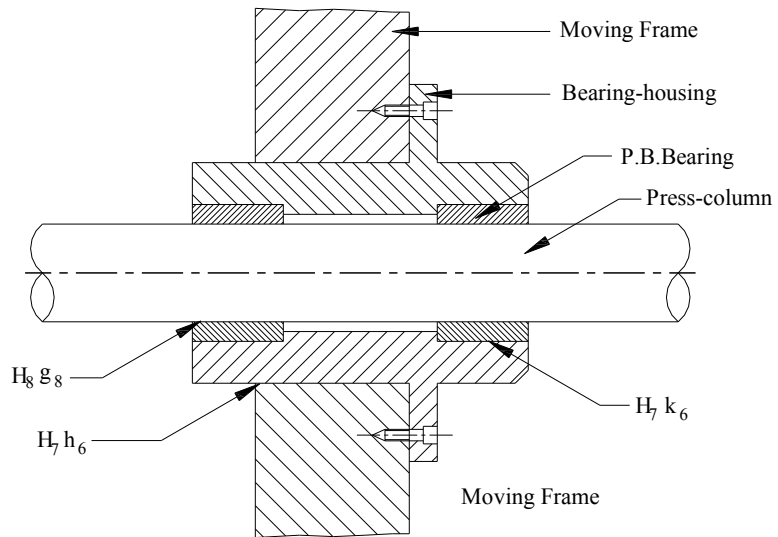

Figure No. 13.2

## Chapter - 14

# Preferred Number

### Importance of Preferred Number :-

Inside diameter of cylinder is selected as 10, 16, 25, 40, 63, 100, instead of 10, 25, 50, 75, 100. Odd figure such as 16, 63 etc. are given more preference over round and easy figure such as 25, 50, 75 because 16 and 63 belongs to preferred number.

Ram dia, seal, capacity of press etc. are selected as per preferred number. Hence as a designer of machine tool and hydraulic press we must have basic knowledge of preferred number.

### Introduction: -

When a press or machine is to be made in several sizes and different capacity. And minimum type, or size, or capacity should covers vast range, then it is found that when a geometrical progression is followed in selection of size then it efficiently cover a optimum range.

Indian standard IS-1076-1967 has specified four basic series as R5, R10, R20, R40, as given below beyond this range other derived series may be obtained from basic series by simply multiplying or dividing by 10 or 100 etc.

Preferred Number or Basic Series			
R5	R10	R20	R40
1	1	1	1
			1.06
		1.12	1.12
			1.18
		1.25	1.25
			1.32
		1.4	1.4
			1.5
1.6	1.6	1.6	1.6
			1.7
		1.8	1.8
			1.9
	2	2	2
			2.12
		2.24	2.24
			2.36
2.5	2.5	2.5	2.5
			2.65
		2.8	2.8
			3
	3.15	3.15	3.15
			3.35
		3.35	3.35
			3.75
4	4	4	4
			4.25
		4.5	4.5
			4.75
	5	5	5
			5.3
		5.6	5.6
			6
6.3	6.3	6.3	6.3
			6.7
		7.1	7.1
			7.5
	8	8	8
			8.5
		9	9
			9.5
10	10	10	10

## Chapter - 15

# Surface Roughness

### Importance of Surface Finish: -

Hydraulic press works on high pressure hydraulic fluid which required to be sealed and press has so many moving components rubbing each other. If importance of surface finish is not understood, and surface roughness not measured and controlled correctly in manufacturing hydraulic cylinder and over-all press then even with best material used also, seals and guides will fail in very short period of time. In following paragraph we will study various allowable surface roughness and its measurement.

Whenever a surface is machined, it has tool marks and micro-irregularities on its surface. Generally it is in form of peak of hill and valley. As per Indian standard surface roughness is measured in terms of **Center Line Average** method, and it is denoted by  $R_a$ . It is average value of the ordinates between the surface and the mean line, measured on both sides of it.

$$\text{CLA value or } R_a \text{ in micron) } = \frac{y_1 + y_2 + y_3 + \dots + y_n}{n}$$

When  $y_1 + y_2 + y_3 + \dots + y_n$  are the ordinates measured on both sides of the mean line and  $n$  are the number of ordinates.

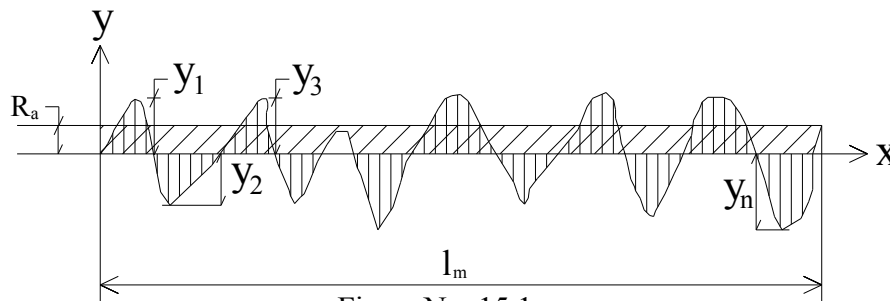

Figure No. 15.1

$R_a$  is also known as Arithmetic center line average. For more detail DIN 4762, 4768, ISO 3274, 4287, 4288 could be referred.

Other method of roughness measurement is Average peak to valley roughness. It is arithmetical mean of the individual peak-to-valley roughness of 5 adjacent individual measured lengths. It is denoted by  $R_z$ .

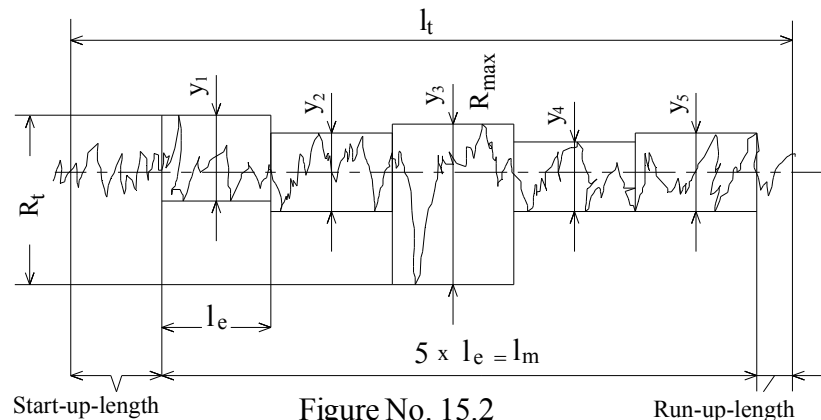

Figure No. 15.2

**Note :-** Incase of  $R_a$ ,  $y_1 + y_2 + y_3 + \dots y_n$  etc. corresponds to the height of a rectangle, whose length is equal to the reference length  $l$ , and where surface area corresponds to the sum of the surface enclosed between roughness profile and center line.

While in case of  $R_z$  it is height of individual peak and valley in arbitrarily selected unit length.

Maximum peak to valley roughness is the greatest individual peak to valley roughness, occurring any place in total measuring length. It denoted by  $R_{max}$ .

### 1. Symbol for Indication of surface roughness and position of surface data in symbol.

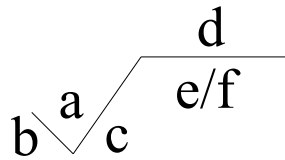

a = Roughness value  $R_a$  in micron

b = Machining allowance

c = groove direction (direction of tool marks with reference to our desired axis).

d = manufacturing process, surface treatment.

e = reference length.

f = other roughness measuring variables  $R_z$ ,  $R_{max}$ . Etc.

2. DIN 4763 and ISO 468 suggest following values of center-line average roughness ( $R_a$ ) in micron ( $\mu_m$ ) 0.025, 0.05, 0.1, 0.2, 0.4, 0.8, 1.6, 2.5, 3.2, 6.3, 12.5, 25, 50.

a) In case of honed hydraulic cylinder tube, we generally keep surface roughness ( $R_a$ ) between 0.2 to 0.4 micron. And maximum upto  $0.8 R_a \mu_m$ .

b) In case of ground and hard-chrome plated piston-rod, we keep surface roughness ( $R_a$ ) between 0.1 to 0.4 micron.

c) In case of cylinder, the roughness groove directions are crossing each other and at  $45^\circ$  to central axis.

d) In case of seal groove, bottom of groove should also have surface finish  $R_a 0.8 \mu_m$ , or less as o-ring and composite seal etc. makes movement in seal groove.

e) In case of seal pocket for stationary seals such as u-seal etc. the seal pocket wall of stationary side of lip should have at least surface finish of  $R_a 1.6 \mu_m$ .

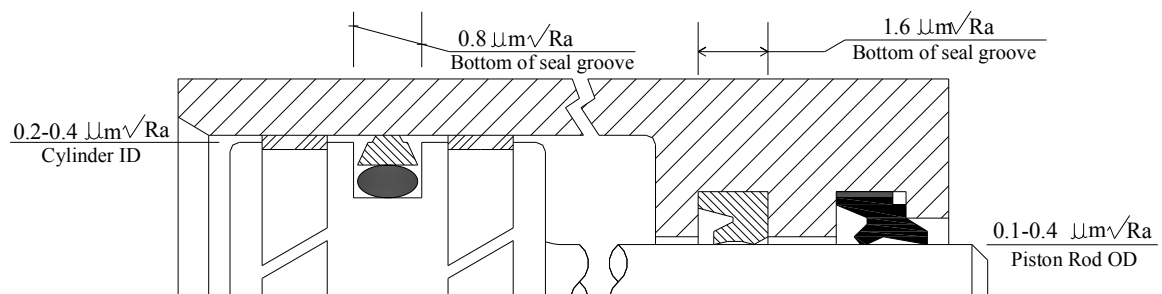

Figure No. 15.3

**Chapter - 16****MATERIAL USED IN HYDRAULIC PRESS****16.1 Introduction: -**

Any engineer who has indepth knowledge of metal and their physical and mechanical properties can himself decide which material could be used for any particular part of a hydraulic press.

Purpose of this chapter is to share the experience and knowledge, which we acquired in long period of time while manufacturing hydraulic presses. Various types of alloys could be used to manufacture different parts of a hydraulic press, which will serve the purpose. But in this chapter we will discuss which particular material best suits to a particular component, with reference to low cost, good strength, and easy in availability and processing.

First briefly we will describe the materials and their properties, then we will discuss in detail various material and alloys used in hydraulic press.

**16.2 Classification of Engineering Material: -**

Engineering materials are classified as: -

- 1) Metals and, their alloys, such as copper, steel aluminum etc.
- 2) Non-metal such as plastic, rubber, glass etc.

Metals are further classified as.

**a) Ferrous Metal: -**

Ferrous metals are those, which has iron as their main constituent.

**b) Non-Ferrous Metal: -**

Non-ferrous metals are those, which have a metal other than iron as their main constituent.

**16.3 Ferrous Metals:-**

The principal raw material for all ferrous metal is pig-iron which is obtained by smelting iron ore, with coke and limestone, in the blast furnace. Principal iron ores are magnetite ( $\text{Fe}_2\text{O}_3$ ), Hematite ( $\text{Fe}_3\text{O}_4$ ), Limonite ( $\text{FeCO}_3$ ), Siderite [ $\text{Fe}_2\text{O}_3 (\text{H}_2\text{O})$ ].

Pig-iron is further re-melted, purified, and alloyed to get various forms of iron and its alloys such as cast iron, steel, alloy steel, stainless steel, heat resistance steel and tool steel etc.

**16.4 Cast Iron: -**

The cast iron is obtained by re-melting pig iron with coke and limestone in a furnace known as cupola. It is basically an alloy of iron and carbon. The carbon content in cast iron varies from 1.7 percent to 4.5 percent. It also contains small amount of manganese, silicone, sulphur and phosphorous. The properties, which make cast iron valuable, is its low cost, good casting characteristic, high compressive strength, wear resistance and excellent machinability.

Ultimate strength of cast iron is as follows:

Tensile strength 1000 to 2000  $\text{kg/cm}^2$ , compressive strength 4000 to 10,000  $\text{kg/cm}^2$  and shear strength 1200  $\text{kg/cm}^2$ . As tensile and shear strength is low hence it could not be used in those parts, which are subjected to tensile, shear or shock load.

The various types of cast iron are gray cast iron, white cast iron, mottled cast iron and alloy cast iron, but in hydraulic press mostly we use gray cast iron.

### 16.5 Gray Cast Iron :-

It has following composition

carbon	: 3 to 3.5 %
silicon	: 1 to 2.75%
manganese	: 0.40 to 1.00%
phosphorous	: 0.15 to 01.5%

The remaining is iron.

The gray colour of metal is due to carbon being in form of graphite. It has low tensile strength, high compressive strength and no ductility. It has good machinability.

In hydraulic press it is being used for side guides, gland-bush, piston and moving plate etc.

### 16.6 Carbon Steel: -

A carbon steel, in defined as a steel, which has its properties mainly due to its carbon content and does not contain more than 1.5 % of manganese. It has no or very less percentage of element such as silicon, phosphors, sulphur. Carbon content in plain carbon steel is maximum up to 1.5 %, the carbon occurs in form of iron carbide, which increase the hardness and strength of the steel.

Plain carbon steel is broadly divided into four categories depending upon carbon content as follow.

- 1) Dead mild steel : upto 0.15% carbon.
- 2) Low carbon or **mild steel** : 0.15 %to 0.45% C.
- 3) Medium carbon steel : 0.45% to 0.8% C.
- 4) High carbon steel : 0.8% to 1.5% C.

### 16.7 Mild Steel :-

Indian standard has divided four above-mentioned major groups into many grades. But in construction of press body of hydraulic press we generally use only low carbon steel or mild steel.

Mild steel with 0.15 to 0.35 % carbon and 0.3 to 0.9% manganese is general-purpose steel. Angel, channel, flat, I-beam etc., which we get from small rolling mills are all this grade of steel. The material has good weldability and used for general-purpose fabrication. This is used, when load on steel is less.

Mild steel with 0.35 to 0.45% carbon and 0.6 to 0.9% manganese is called C40 as per ISI designation and EN8 in British standard. It is economical and easily available in market. In hydraulic press this metal is wildy used for column, nut, cylinder and flange etc. For those components, which require welding, the carbon content selected below 0.4%.

Steel with 0.45% to 0.6% carbon and manganese continues 0.3 to 0.9% is classified as C50 and C55 in ISI standard and nearest British standard is EN9. This is also economical and easily available. This is used where high strength is required with good wear resistance. This metal also could be heat treaded.

IS-2062 grade M.S. This is a grade of mild-steel, which has good weldability. Hence mostly steel plate, rolled section etc. used in hydraulic press is of this grade.

### 16.8 Effect of Alloying Element on Properties of Steel: -

All though metal and alloys have been classified in most systematic way and their constitution has been defined in details by standard setting authority. But in actual practice what material available at small metal merchant are from small rolling mills and foundries, who are unable to control the percentage of various elements correctly. Some time good and large size of metal shaft and plate are also available from old ship breaking yard or scrap. All these metals could be tested in laboratory and percentage of its various element could be determined. But when some one is fully familiar with the element their permissible limit in iron, their effect on mechanical properties and in which grade these “iron alloys” could be classification, then only one can decide its weldability, heat treatment ability, and for which part of press it could be used. Hence in following paragraph we are describing various elements and their effect on iron.

**A) Silicon :-**

The amount of silicon in the finished plain carbon steel usually range from 0.05 to 0.35 % silicon is added in low carbon steel to prevent them from becoming porous, it makes the steel tougher and harden.

**B) Sulphur :-**

It should be as low as possible in steel as it produces red shortness it should not be more than 0.3%.

**C) Manganese :-**

In low carbon steel manganese increase strength and toughness. It combines with sulphur and thereby decreases the harmful effect of element in steel. Higher percentage of manganese makes steel brittle and produces cracks in welding joint.

**D) Phosphorous :-**

It makes the steel brittle, it also produces cold shortness in steel.

**Following Elements are added in Steel to improve its Properties.**

**a) Nickel: -**

It increases the strength of steel and toughness of the steel.

**b) Chromium: -**

It is added to increase hardness with high strength and high elastic limits. It also increases corrosion resistance.

**c) Tungsten: -**

It prohibits grain growth, increases the depth of hardening of quenched steel and it conforms the property of remaining hard even when heated to red-hot. It is used in cutting tools.

**d) Vanadium: -**

It increases strength and elastic limit without loss of ductility in medium carbon steel.

**e) Cobalt: -**

It increases hardness and strength, and retains hardness even at high temperature.

**f) Molybdenum: -**

It increases tensile strength.

## 16.9 Hydraulic Press Component and Their Material of Construction: -

Sr. No.	Press-Component	Requirement	Material to be used
1	Main shell	<p>(1) General purpose and common cylinder shell should be weld able, to weld flange. And should be of ductile material to avoid sudden cracking and blasting.</p> <p>(2) For high pressure cylinder when over all dimension has to be controlled to minimum, then alloy steel is used.</p> <p>(3) Barrels of plastic injection Moulding machine, which withstand pressure as high as 1500 Bar and high temperature.</p>	<p>ASTM-106A Grade</p> <p>EN-24 Harden and tempered. To 35-40 RC</p> <p>EN-41B Heat-Treated And Nitrided</p>
2	Welded-Flange	Material should have good weld ability.	IS-2062
3	End-Plug	<p>(1) If end-flange is to be welded then it should have good weld ability.</p> <p>(2) If end-flange is to be bolted then it should not be brittle.</p>	<p>IS-2062</p> <p>M.S/EN8</p>
4	Piston	<p>Piston rubs inside surface of cylinder, hence it should have bearing material property. It also withstand the load developed by cylinder hence it should have good strength.</p> <p>(1) When only plain metal to be used.</p> <p>(2) If brazing-lining could be applied on piston surface.</p> <p>(3) When guide-ring etc. could be used On piston</p>	<p>C.I. (Gray Cast Iron)</p> <p>M.S/EN-8 with lining of bearing material.</p> <p>M.S./EN8 with Guide-Rings</p>
5	Guide-bush	Guide-bush also with stand full load developed by cylinder in case of fully extended stroke. Hence it should have high strength, weldable and should not be brittle.	M.S/EN-8
6	Gland-bush	Gland-bush guides the piston-rod as well as it retain gland-seal. Hence inner surface of gland-bush should have lining of bearing material as well as it should have good strength.	<p>Cast iron.</p> <p>M.S/EN-8 of bronze or fitted with Guide-Ring of bronze filed PTFE or other similar standard material available with seal manufactures</p>
7	Bolts	Bolts withstand full load developed by cylinder hence all bolts used in press should be high tensile type.	High-tensile Bolt of 10.6 or 12.9 grade. Made from EN-2 or EN-9
8	Seals	Hydraulic seals avoid the leakage of highly pressurized oil. Life of hydraulic system also depend on and performance of seal. Hence seals are carefully selected as per the working condition of system.	Fiber impregnated high nitrile seal/Polyurethane Bronze filled Teflon and Special Material developed by seal manufacturing.
9	Columns & Nuts	Columns withstand full load developed by cylinders. Also in each production cycle stress in column varies from minimum to maximum.	M.S./ EN8 for general-purpose press.

10	Column - Guide	Guide move on column or guiding surface. They should have bearing material property as well as should have good strength.	C.I., EN-9/EN-24 for special purpose compact presses. Phosphors bronze bush/or bronze filled PTFE
11	Press Body	Press-body withstand load developed by cylinder. Also load is variable in each cycle.	Fabricated structure should be fabricated from IS-2062 steel Plate. Casted body such as injection-Moulding machine should be casted in steel casting of EN-8 grade/or better grade.
12	Press-Tools	<p>(1) Pressing Dies for Bending etc. (medium load)</p> <p>(2) Pressing Dies for Bending for high load.</p> <p>(3) Such tools where hard-surface and tough core required.</p> <p>(4) Such tools where hard surface and high strength required (Cutting Blades etc.)</p>	<p>EN-9 Harden and Tempered</p> <p>EN-24 Harden and Tempered (45-50 RC)</p> <p>EN-36 Core-Toughen and case carbonized (surface hardness 55 RC, core hardness 35-40 RC)</p> <p>HCHCr (High Carbon High Chromium) also known as WPS. Harden and Tempered (55-58 RC hardness)</p>
		(5) Cutting Blade for shearing thick Steel Plates	pneumatic steel or high speed steel harden to 55-57 RC

## 17. Heat-Treatment

In manufacturing of hydraulic presses we do following types of Heat Treatment.

1. **Annealing:** - It is done for the softening of the material before machining of forged and difficult to machine material.
2. **Normalising:** - It is done to relieve the stress set-up due to welding etc. and refine the grain structure of component to improve their strength.
3. **Hardening:** - It is done to harden die, punch, plunger, container and various component of hydraulic press.
4. **Tempering:** - It is done to harden material to relieve the stress developed due to quenching and to reduce brittleness.
5. **Case-Hardening:** - Carburising and nitriding is done to increase the surface hardness of component, while core still remain soft and ductile.

### 17.1 Annealing: -

It is a softening process in which iron base alloys are heated above the upper critical temperature range, held there for a proper time and then cooled slowly (at the rate of 30 to 150 °C per hour) below the lower critical temperature range in the furnace itself.

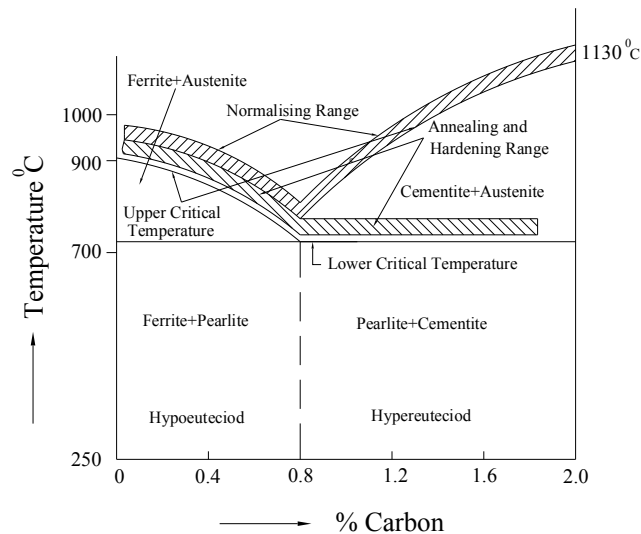

Figure No. 17.1

Heating is done 20 °C above upper critical temperature of steel in case of hypo-euctoid and steel 20 °C above the lower critical temperature in case of hyper-eutectoid steel. Article is held at above mentioned temperature for ½ to 1 hour period then cooled slowly.

On cooling, hypo-eutectoid steel produces pearlite and ferrite, hyper-eutectoid steel produces pearlite and cementite. Due to presence of pearlite the material become soft.

### 17.2 Normalising: -

In normalizing we heat both hypo as well as hyper-eutectoid steel 40 to 50 °C above upper temperature range, kept their for sufficient time so that complete mass gets uniformly heated up and then cooling the article out side furnace in still air at room temperature.

On cooling hypo-eutectoid steel will have ferrite+pearlite grain structure and hyper-eutectoid steel will have pearlite+Cementite grain structure. But they will not have any harder grain structure such as martensite etc.

Welding, cold-working and forging etc. produces coarse and elongated grains, and welding of fabricated structure produces residual stress in structure. Normalizing is done to produce uniform fine grain structure and eliminate the residual stress.

### 17.3 Hardening: -

Hardening is done to increase the wear resistance and increase the tensile strength of component. (This also reduces ductility and toughness).

For hardening, article is heated about 20 °C above upper critical temperature in case of hypo-eutectoid steel and 20 °C above lower-critical temperature for hyper-eutectoid steel. Heating convert all the ferrite in to austenite.

Solution of austenite and cementite then cooled at the rate of app. 200 °C per minute.

At this cooling rate pearlite cannot be formed, hence martensite grain structure get produced. Martensite is extremely hard. Hence mass of article get hardened.

### 17.4 Tempering: -

Tempering is a re-heating process of hardened component bellow the lower critical temperature range. It is done for two purpose.

1. To reduce the internal stress produced due to quenching of component.
2. To change the hardness of components as per requirement.

For tempering component may be heated from 200 °C to 550 °C depending on requirement. Due to heating martensite start converting in to softer grain structure such as sorbite etc. Hence hardness also starts reducing. By controlling the re-heating temperature limit and then cooling rate we control and get the desire hardness of component.

### 17.5 Case-Hardening: -

In many applications we require soft core and hard surface of a component in hydraulic press. Soft core avoids breaking of component and hard surface gives resistance against wear and gives long working life.

In such case case-hardening is done. Case-hardening could be casburising or nitriding.

In case of carburising we induce atom of carbon in lattice structure of iron, and in case of nitriding we know atoms of iron has fixed type of atomic patterns, that is body-centered cubic atomic structure bellow 700 °C. This pattern can accommodate only 0.025% carbon atoms. At this percentage of carbon atoms iron has flexibility to move. Hence iron remains ductaile and soft.

When we forcefully induce more carbon or nitrogen atom between these cubic lattice structure of iron, atom of iron do not have space to move and loose their flexibility, and iron becomes hard. And as we carry out this forceful induction of atom of carbon and nitrogen only on surface hence only surface of iron gets harden, and core remain soft.

For carburising iron, heat at 900 to 950 °C with charcoal semi-coke, peat coke, barium carbonate ( $\text{BaCO}_3$ ) and soda-ash ( $\text{Na}_2\text{CO}_3$ )

While for nitriding iron is heated at 600 to 650 °C for prolonged period in an atmosphere of  $\text{NH}_3$ .

In hydraulic press we case-carburise EN-36, for making tools of crimping machine, while barrel of injection moulding machine is made EN41B and nitrided.

## Chapter -18

## 18. Welding Technology

## 18.1 Welding in Hydraulic Press: -

Welding technology is a vast subject. There are many types of welding processes. Each process may require a complete volume of book to describe it. It is not possible for us to describe the basic welding technology. In this chapter we will only revise some of the welding knowledge, which you already have, and which are related to and important in manufacture of hydraulic press.

## 18.1.1 Importance of Welding in Hydraulic Press: -

In old days press body and cylinder were steel casted, machined and assembled. But nowadays only few type of standard presses are steel casted and most of the presses have steel fabricated body. Hydraulic cylinders are also welded.

Hydraulic press body and cylinders are extremely stressed structures, undergo constant fluctuating and dynamic loading. The thickness of plate and shell is also more, which are difficult to weld. If welding technique and welding rod are selected and used incorrectly, then whole press may fail due to structural failure. Hence knowledge of welding rod, welding technique, cause of welding cracking and its remedy are very important for successful design and manufacturing of a hydraulic press. In this chapter we will discuss only the commonly used type of welding process, that is "Welding by flux core welding rod".

## 18.2 Principal of Welding by Core Welding Rod: -

An arc is setup between flux coated welding electrode and work piece. Heat of arc melts the joining base metal and core wire of electrode, which gets fused in molten condition. Flux protects the arc and molten metal till they get solidifies, to produce a strong and sound joint.

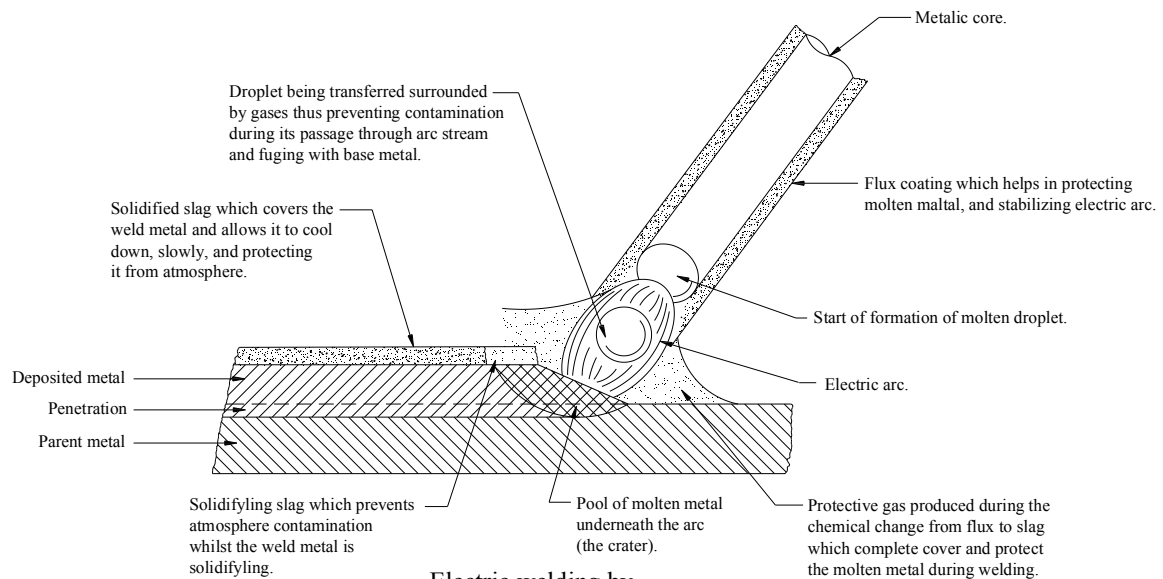

Electric welding by  
Flux cored welding electrodes

Figure No. 18.1

### 18.3 Introduction to Matter and their State: -

As most of the factors on which strength of weld depends are composition of base metal, composition of core wire of welding rod, alloying element in base metal, grain structure of welded joint, and grain structure of surrounding heat effected zone of base metal. Hence to understand this factor we must have basic knowledge of metallurgy. In following paragraph we will briefly describe metallurgy, the knowledge that is important and related to welding.

#### 18.3.1 Matter: -

Ancient philosophers thought that all matters are derived from just five substance, Earth, Water, Air, Fire and ether (space or sky). But with development of chemistry it is found that all matter on our earth are build up of many pure substances, which are called Elements. There are total 102 elements. Out of 90% of the earth's surface main elements are Oxygen 50%, Silicone 26%, Aluminum 7%, Iron 4% and Calcium 3%.

#### 18.3.2 The States of Matter: -

The smallest possible partical of pure element is called ATOM. It consist of a positively charge nucleus, surrounded by a negatively-charge cloud formed by electrons revolving around the nucleus. The positive and negative forces are balanced, so that the atom as a whole is electrically neutral.

When atoms combine they form the smallest possible particle of a compound, which is given the name as MOLECULE. The number of atom in molecule depends upon class or type of matter. Only in metal do we find just one atom in a molecule.

Matter may occur as solid, liquid or gas. In case of solid, molecules have great attraction for each other, and although in state of continuous vibration they form a set pattern giving the solid a definite shape, and they offer resistance to any attempt to change that shape.

In case of liquid these inter-molecular attraction is relatively less, hence molecules do not firmly hold each other, but allow relative movement, matter deform easily and take shape of container in which it is placed in liquid form. In case of gaseous state, there is very less attraction between molecule hence they do not have any shape.

#### 18.3.3 Forms of Element: -

The basic 102 elements could be divided in to three categories, namely, metals, metalloids and non-metals. Example of metal is Gold, Silver, Copper, example of metalloids is Carbon, Boron, Silicon etc. example of non-metal is Oxygen, Phosphorus, sulphur etc.

These three types of element may co-exist in two forms that are **Mixture** of two elements and **Compound**.

#### 18.3.4 Mixture: -

In case of mixture two elements are thoroughly mixed with each other as a homogenous mass. But the small particle of individual element retain their basic properties, they could be separated again by suitable means to their natural pure state. For example powder of iron and sulphur could be mixed with each other to form a mixture, but if a magnet is passed through this mixture, iron particules will again separate out and get attracted to magnet, only sulphur powder will remain in container.

### 18.3.5 Compound: -

In case of compound two elements combined chemically and forms a third substance. Which do not posses any property of basic pure elements. For example if iron and sulphur are mixed in 7 to 4 ratio and heated then iron-sulphid will form which has properties other then that of iron or sulphur.

Hence a mixture can be defined as a number of elements or compounds in close proximity with each other without making any chemical interaction. They are allowing separation to take place without great difficulty.

A compound is produced by the atomic combination of elements, and the resulting substance has different property then basic element from which it has been formed. And it is difficult again to decompose and form again principle elements. As water is a compound form by oxygen and hydrogen. In a weld joint we find the metal exist in both the above two form. Iron combines with carbon to form compound called **Iron carbide**, said compound remains in mixture form with solid solution of iron and carbon called **Ferrite**.

### 18.3.6 Metal and their Alloys: -

To improve the mechanical property of a metal other elements are added in it. These added metal may dissolve completely in base metal in molten state and is called **Liquid Solution**.

The solubility, which is achieved in molten state may remain in solid state. On solidification such combination or state of metal is called **Solid Solution**.

Some time solubility of alloying element decrease as base metal solidify. In such case alloying element partially separately or precipitate out from base-metal. Hence on solidification base-metal will consist of Solid-Solution, pure metal and pure-alloying element.

In some cases the alloying element not only remains dissolved in base-metal but also combines with it on atomic level and forms a hard and brittle alloy called "**Inter-Metallic Compound**".

Above all three states will come in picture when we study weld metal. Pure iron is base metal, carbon as alloying element, carbide is inter-metallic compound and they will exist in all the state discussed above in weld deposit.

### 18.3.7 Formation of Grains in Solids: -

Metals are crystalline in nature. That is when it starts solidifying it just do not form lumps of homogenous mass and get solidified. But metal solidification process is systematic and well defined.

First few atom near the initial cooling zone form nucleus and other atom start collecting around it in systematic and symmetric way, more and more atom joint them and they grow larger in volume in form of a radial arm or star. Then each arm grows and at periodic interval they again form secondary arms at right angle. This result in formation of a **Crystal** where appearance is likes a fir tree. Hence some time these crystals are also referred as fir tree crystal. The correct names of such crystals are **Dendrites**.

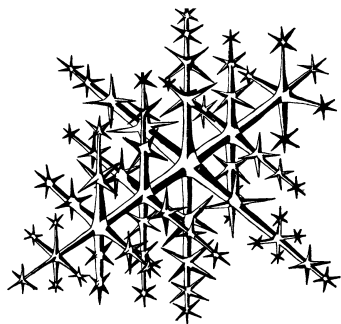

Dendrites Figure No. 18.3.7

Ultimate grain boundaries

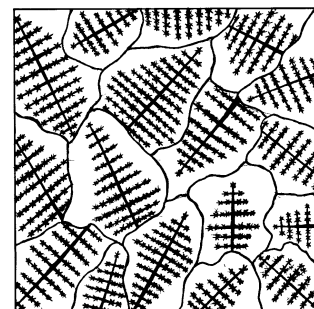

Figure No.18.3.7 (a) Dendrite Crystals

As crystal formation starts at number of places at a time. Hence as they grow longer they come in contact with branches of other crystal. This brings about restriction of crystal growth. Hence after this stage crystal could not grow in systematic pattern, but just fill all the un-solidified spaces. On solidification no trace of original fir-free crystal could be found but only irregular spherical. There irregular spherical crystalline structure is called **Grain**.

1. Few Crystals Formed
2. Crystal grow larger
3. Crystal touching each other
4. All the space between dendrites (crystal) filled and grains formed.

Following figure No.13.3 will show a schematic diagram of solidification of metal from molten start to grain formation.

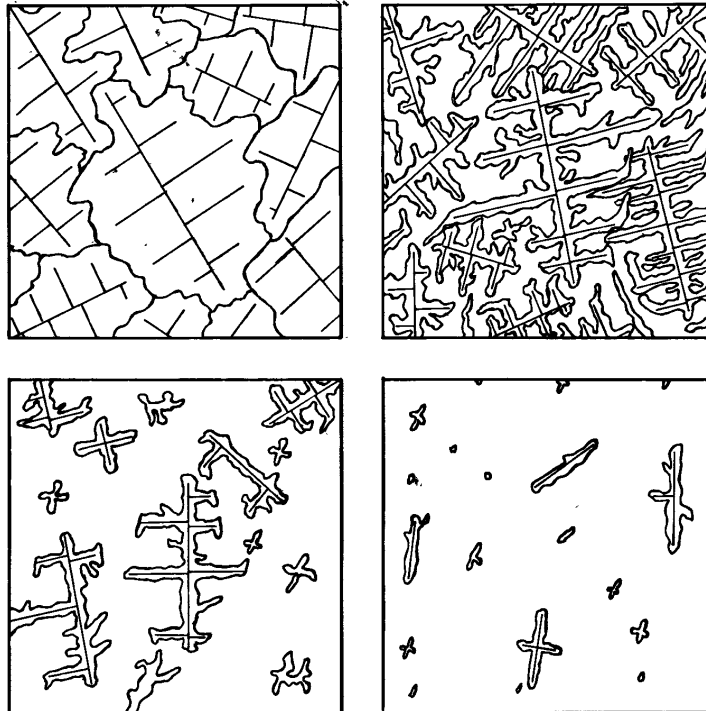

Figure No. 18.3.7 (b) Grain Formation

### 18.3.8 Grain Growth: -

When molten metal is poured in a mould for casting. Molten metal which come in contact with cold walls of mould start solidifying immediately. Many nuclii forms in outer layer, and a layer immediately solidifies. Resulting in a mass made up of many small crystalline grains generally referred as **Fine Grain**. After this, solidification progress in-word toward center. First nuclii forms adjacent to outer solidified layers, as crystallization begins the crystal immediately come in contact with adjacent crystal in lateral direction hence crystals get space for growth only in one direction, that is longitudinal direction toward center. Hence the resulting crystal grains are not spherical but elongated. Such grains are called **Columnar Grain**.

The continuation of heat loss through out the mass will so reduce the internal temperature that simultaneous freezing of the remaining molten metal will now take place at central zone. The seed of crystal that is nuclii forms in all the remaining molten metal. They grow in all the direction, as they do not have restriction from any side. Two solidified layers that is fine grain and columnar grain acts as casing, though solidified but still hot enough, hence solidification time of inner core is maximum as compared to outer layer. Crystallization process continues for longer period. Hence the grain is also growing to large size. As crystal of central portion grow equally in all the direction hence they are also refer as **equi-axed**, and as they are large in size hence also called as **coarse grain**.

A sectional view of cast ingot clearly shows the three type of crystal formation. Same process also occurs while solidification of weld metal. Coarse grains decrease the ductility and tensile strength of metal. Hence always fine grains are desired.

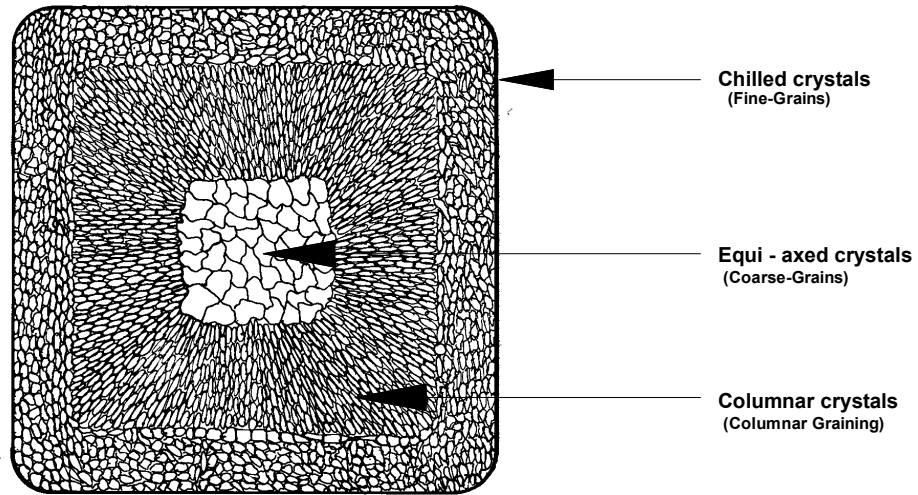

Figure No. 18.3.8  
 Casted Ingot of Pure Metal Showing  
 Three Type of Crystal Structures

**18.4 The Iron Carbide Equilibrium diagram: -**

Iron is an allotropic metal, which means that it can exist in more than one type of atomic arrangement structure (lattice structure) depending upon temperature. A cooling curve for pure iron is as shown in following figure.

**18.4.1 Physical Properties of Iron: -**

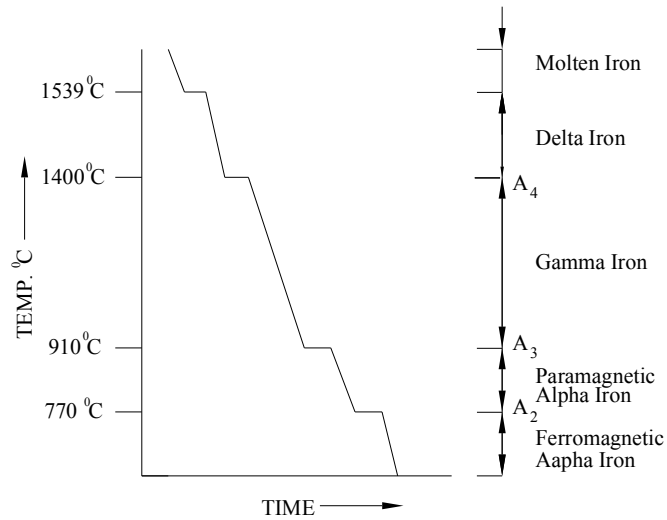

Figure No. 18.4.1

1. Melting point	=	1539 °C
2. Boiling point	=	2740 °C
3. Density	=	7.87 gm/c.c.
4. Thermal conductivity at 20 to 25 °C	=	0.19 cal/sec/sq cm/°C/cm
5. Electrical conductivity at 20 to 25 °C	=	100,000 micro-ohms/c.c.
6. Young's Modulus of Elasticity	=	2,000,000 kg/cm <sup>2</sup>
7. Tensile strength	=	2,350-2,650 kg/cm <sup>2</sup>
8. Yield strength	=	650-1300 kg/cm <sup>2</sup>
9. Elongation in 50mm at 20 °C	=	20 – 45%
10. Reduction of Area	=	70 – 90%
11. Brinell Hardness	=	50 – 70%
12. Impact Strength	=	2.1 m/kg
13. Creep Strength -		
300 °C		1,100 kg/cm <sup>2</sup>
400 °C	=	800 kg/cm <sup>2</sup>
600 °C	=	160 kg/cm <sup>2</sup>
14. Thermal Expansion per degree centigrade –		
100°C	=	0.0000126
300°C	=	0.0000146
600°C	=	0.000016
15. Specific Heat –		
100°C	=	0.12 cal/gm
500°C	=	0.16cal/gm
700°C	=	0.32 cal/gm
900°C	=	18.5 cm/gm
16. Resistivity	=	9.8 micro-ohms/c.c.
17. Maximum permeability	=	28,000
18. Hardenability	=	Can be hardened by very severe quenching.

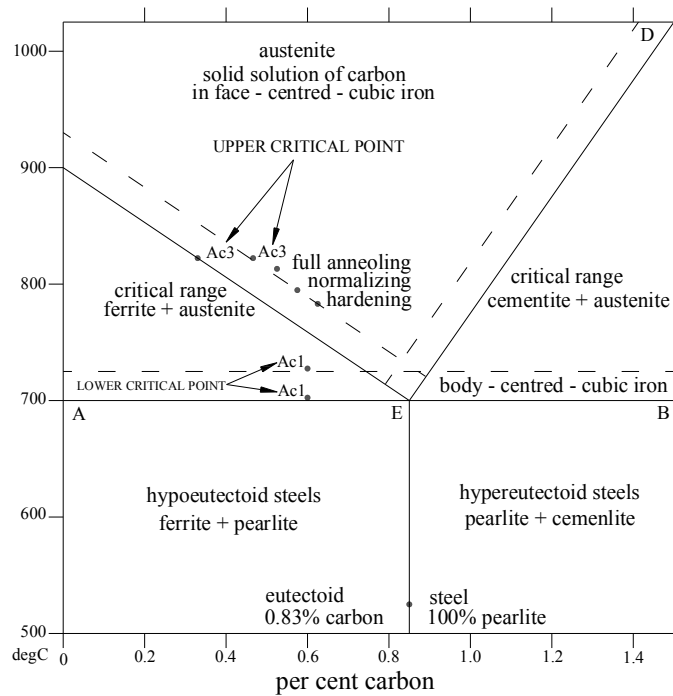

Figure No. 17.4.1 (b)

### 18.4.2 Terms Related to Iron–Iron carbide Equilibrium diagram: -

- 1) Atomic structure of iron (B. C. C. & F. C. C.).
- 2) Ferrite.
- 3) Cementite.
- 4) Austenite.
- 5) Pearlite and its formation.
- 6) Lower critical temperature line.
- 7) Upper critical temperature line.

### 18.4.3 Body-centered Cubic Atomic Structure of Iron and Ferrite (b.c.c.): -

The atomic arrangement of iron below 700 °C. is in the form of Body-Centered cubic (b.c.c.) structure, as shown in following figure. This structure can accommodate less carbon atoms between its b.c.c. Structure. Only 0.025% carbon can be fully dissolved in such structure and form solid solution. Such solid solution is called **Ferrite**. Ferrite is soft and ductile and has hardness only 50 to 100 Brinells.

### 18.4.4 Face-centered Cubic Atomic Structure of Iron and Austenite (f.c.c.): -

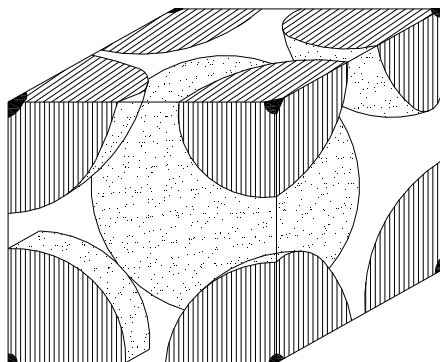

Figure No. 18.4.4

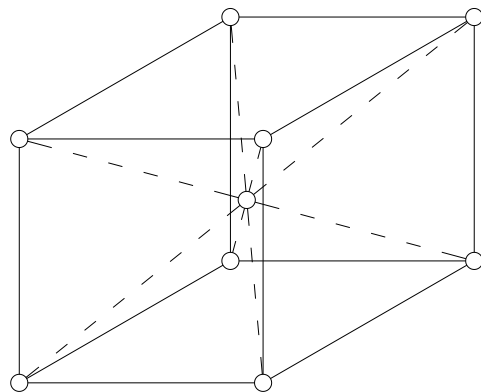

Figure No. 18.4.4 (b) Body Centred Cubic Lattice

As temperature of iron increase the atoms of iron re-arrange them-self and become face-centered cubic structure (f.c.c.) as shown in following figure.

This arrangement of atom can accommodate more atom of carbon between its atomic patterns. 1.7% carbon can dissolve in iron and make solid solution. But this is an unstable state and cannot exist below 700 °C. (lower critical temperature). This solid solution is known as **Austenite**.

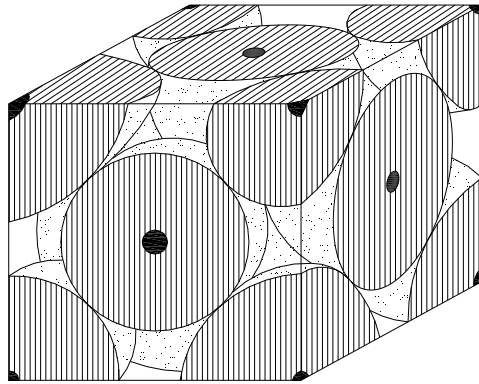

Figure No. 18.4.4 (c)

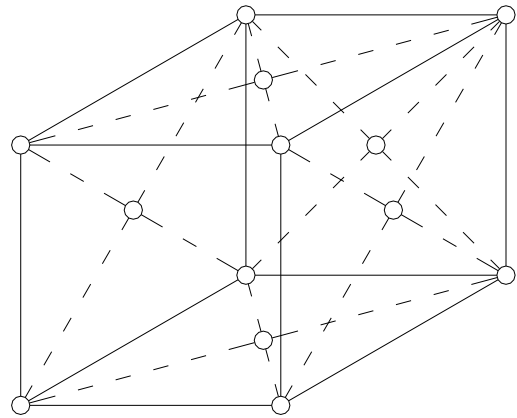

Figure No. 18.4.4 (d) Face Centred Cubic Lattice

#### 18.4.5 Cementite: -

Ferrite we have discussed in b.c.c. iron. It is a solid solution iron with 0.025% carbon. It is soft and ductile. While cementite is an interstitial compound of iron and carbon. It is also called iron-carbide ( $\text{Fe}_3\text{C}$ ). It has 6.67 percent of carbon by weight. Cementite is extremely hard and brittle material. It has hardness 1400 Brinell.

#### 18.4.6 Pearlite: -

When Austenite, which is a solid solution of, face-centered cubic iron and carbon start changing from f.c.c. to body center cubic structure, which has low solubility of carbon. As re-arrangement of atoms progresses from f.c.c. to b.c.c., carbon come out of atomic structure in form ( $\text{Fe}_3\text{C}$ ) cementite, and form a disc or plate like grain. The iron (ferrite) which has just depleted the excess carbon and has only 0.025% soluble carbon also accumulate as a layer on both side of disc or plate like cementite. This process continues till all f.c.c. change to b.c.c.

The alternate layer of ferrite and cementite looks like a fingerprint if observed by microscope, and called as **Pearlite**.

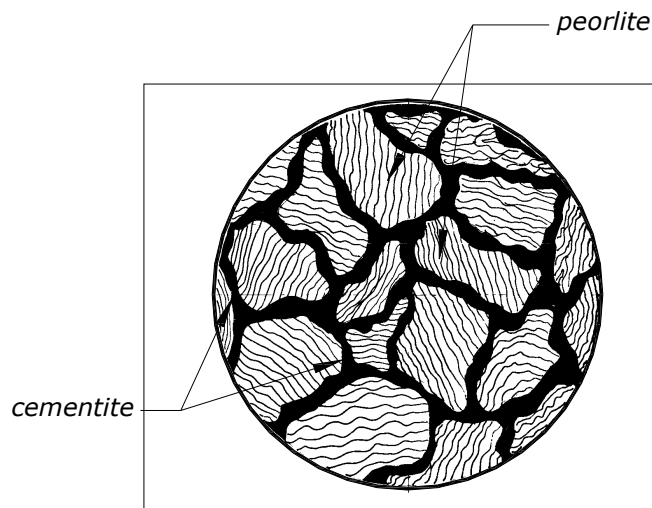

Microstructure of Pearlite(Cementite)

Figure No. 18.4.6

### 18.4.7 Critical temperature: -

When b.c.c. iron are heated, at a particular temperature it starts changing its atomic structure. If it is further heated the changing from b.c.c. to f.c.c. Continue and at a particular temperature all b.c.c. will change over to f.c.c.

The temperature at which change over from b.c.c. to f.c.c. begins is called **lower critical temperature point**. The temperature at which b.c.c. to f.c.c. change over completed is called **upper critical temperature**.

The lower critical temperature is almost constant and same for all the percentage of carbon in iron, while upper critical temperature depends upon the percentage of carbon in iron.

### 18.4.8 Eutectoid point: -

When carbon percent in iron is 0.83%. The change over of atomic structure from b.c.c. to f.c.c on heating, or f.c.c. to b.c.c. on cooling takes place on a single temperature (app 723 °C), and upper and lower critical temperature are same. This point is called eutectoid point. Steel having 0.83% carbon called **eutectoid steel**, iron with less than 0.83% carbon is called **hypo-eutectoid steel**, and iron with more then 0.83% carbon is called **hyper-eutectoid steel**.

### 18.5 Effect of it Heating & Cooling on Granular Structure of Iron: -

We have already studied that when iron-heated up atomic structure of iron changes from b.c.c. to f.c.c. And above upper critical temperature almost all carbon gets dissolve in iron and makes a solid solution, which is unstable and cannot exist at room temperature.

Now if same solution cooled down, we will get various types of grain structure at various temperatures, which depends upon percentage of carbon and rate of cooling. First we will study only effect of carbon, (very slow cooling).

#### 18.5.1 Cooling of Hypo-eutectoid Steel: -

Hypo-eutectoid is that steel which has less than 0.83% carbon. Above upper critical temperature all the carbon is in solid solution with iron known as Austenite with f.c.c. As temperature reaches the upper-critical temperature line, the percentage of carbon austenite can keep is govern by line FD.

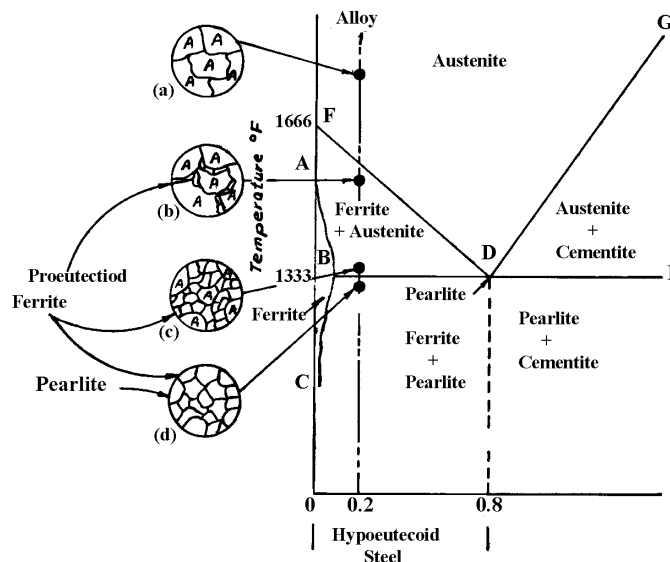

Figure No. 18.5.1 Percent Carbon by Weight →

Below FD line f.c.c. Iron Start changing over to b.c.c. Pattern, which has less solubility of carbon. Hence above FD, all the grain was of Autemite, but below FD, some iron change over to b.c.c. which loose carbon and contain only 0.025% carbon, which is called **Ferrite**. It accumulates on boundary of austenite grains. Whatever carbon dissociated from ferrite gets dissolve in austenite as austenite can accommodates upto 1.5% carbon. When lower-critical temperature reaches, which as line BDE, the austenite which is not changed yet can absorbe upto 0.83% carbon, and it absorbes that much carbon, from other grain converting to ferrite.

Below lower critical temperature f.c.c. structure cannot exist. Hence as temperature drops below this limit, eutectoid reaction takes place in all the austenite grain and change them to fine finger-print like structure of ferrite and cementite called pearlite.

### 18.5.2 Cooling of Hyper-eutectoid Steel: -

Hyper-eutectoid steel is those, which contain more than 0.83% carbon. Various stages of cooling and grain structure is shown in figure.

Above upper-critical temperature DG, iron is Austenite state which is unsaturated iron-carbon solid solution, and can dissolve up to 1.7 % carbon. As soon as upper-critical temperature reaches. This amount of carbon can be dissolve in Austenite is governed by line DG, which indicate that solubility of carbon decrease with decrease in temperature.. Hence with drop in temperature austenite dissipate excess carbon which in form of iron-carbide start accumulating on boundaries of austenite grains.

Just above lower-critical temperature austenite contain 0.83% carbons and excess carbon accumulate on boundary of austenite in form of a networking of iron-carbon. As soon as temperature droops below lower critical temperature eutectoid reaction takes place and all austenite grain converted in to pearlite grains.

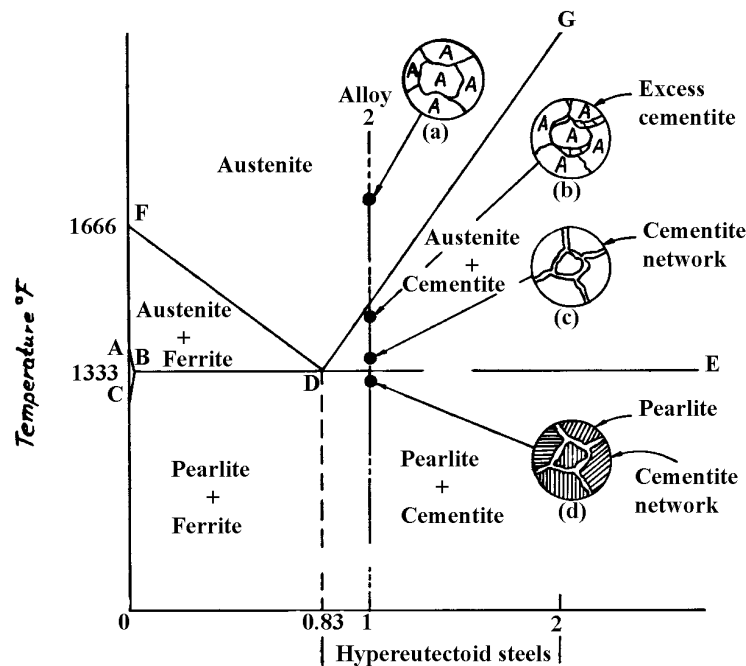

Percent carbon by weight

Figure No. 18.5.2

### 18.5.3 Cooling of Eutectoid Iron: -

Iron with 0.83% carbon called eutectoid iron, when such iron is cooled down nothing happens till lower-critical temperature reaches and whole mass remain austenite with 0.83% carbon. But as soon as temperature drops below lower-critical temperature eutectoid reaction takes place and at same temperature all austenite grain change over to pearlite grain.

### 18.6 Effect of Cooling Rates on Steel: -

At high temperature carbon makes a solid solution with iron and remains completely dissolved in face-centered cubic structure of steel. But if said steel cools down very rapidly (Quenched in cold water) then iron will transform from face centered body lattice to body-center cubic lattice, but carbon do not get sufficient time to precipitate out from body centered cubic structure of iron and get trapped to form an unstable



Figure No. 18.6

and super-saturated state of iron which is very hard, and brittle, and consist of an acicular structure, known as **Martensite**.

To improve this undesirable state of steel, it is again heated so that carbon gets time to separate out and unit free iron to form a more stable state.

When such steel is heated and cooled slightly slower rate than that required to form martensite, then the resulting structure is called **Troostite**. It is slightly softer than martensite but still hard enough. Micro structure consists of long granules of cementite present in martensite.



Microstructure of Troostite  
Figure No. 18.6 (a)



Figure No. 18.6 (b)

When cooling rate is further slower than that required to produce the **Troostite**, then **Sorbite** will form. This structure consist of a mixture of small un-oriented particle of cementite and ferrite.

A pearlite consists of laminer structure of cementite and ferrite while a sorbite has granular structure of cementite and ferrite.

**Sorbite** is not hard as **Troostite** but it is tough with good in over-all strength.



Microstructure of Austenite  
Figure No. 18.6 (c)

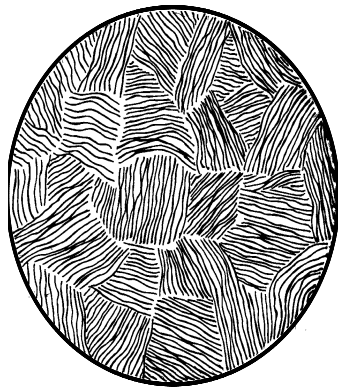

Microstructure of Pearlite(Eutectoid)

Figure No. 18.6 (d)

Hence the resulting structure obtained by cooling **Austenite** depends upon rate of cooling. If is very fast then very hard martensite will form, as rate of cooling slows down then **Troostite**, **Sorbite** or **Pearlite** will form.

If Martensite is cooled very slowly then all the carbon will come out from solid solution and form alternate layer of cementite and ferrite and form **pearlite**.

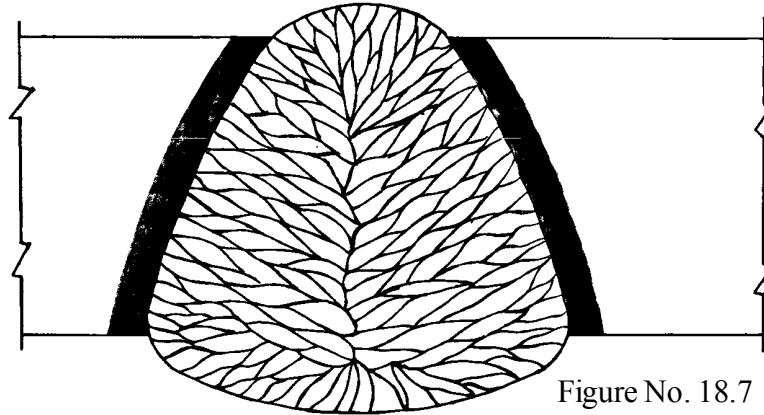

Figure No. 18.7

Above details explain how important is heating joint before welding, and controlling its cooling rate. A rapidly cooled joint may have hard marten site or troostite structure, which is hard and brittle, and joint will fail as soon as load applied.

Even after taking all the precaution some time welded joint and heat-affected area near welding gets heated. In such case welded structures is heat treated to remove all harden zones.

In chapter of heat treatment we will study the various process of heat treatment used in fabrication and while manufacturing hydraulic presses.

#### 18.7 Granular Structure of Welded Joint: -

A welded joint can be considered as a castled structure, and process and sequence of grain formation is same as those of casting.

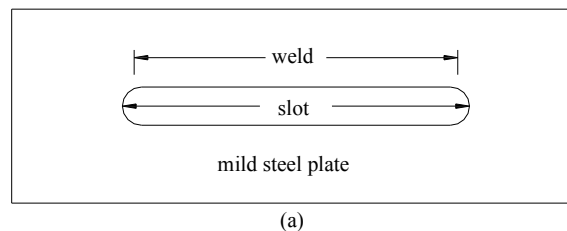

(a)

Figure No. 18.8

Under the intense heat of arc core of welding rod melts, and get collected in joint of base metal. The molten metal first comes in contact with base metal which is much cool, hence solidification starts from base-metal, and propagates from both side of weld deposit toward center. As each grain grows it come in early contact with lateral grain, hence growth is mostly in longitudinal direction. Hence grain produced is of columnar type. Which is weaker than fine structure.

In case of welded joint in which number of welding presses has to be made. The new welding process heats the last weld deposit above upper critical temperature, because of which re-crystallization takes place and helps in formation of fine equi-axed grain structure, which has much, more strength then columnar grains.

#### 18.7.1 Analysis of the Heat-affected Zone of the Parent Metal: -

A welded joint can be considered as a casted structure, welding rod and base-metal first melt and then solidify. Iron melts as 1539 °C Electric arc produce very high temperature, hence temperature may be more than 1539 °C. These heated and molten masses of iron also affect the surrounding area of base metal.

These heat affected zone for simplicity we divide into four zones as follow.

**a. Weld metal deposition: -**

Due to heat produce due to electric arc welding rod gets melted and get deposited in the joint of base metal. When weld metal solidify they have elongated or columnar grain structure as shown in figure and as we have studied in case of billet casting. Solidification starts from base metal and prolongates toward center of deposit metal.

**b. Over Heated Zone: -**

This zone start from fusion line, which is junction between weld dilution and unmelted base metal to the base metal, which reached temperature very, near to melting point. In this zone severe grain growth takes place due to over heating, which reduce the mechanical properties of base-metal unless joint is again heat treated. Coarse grain structure is known as **Widmanstatten structure**.

**c. Refining Zone: -**

This zone starts from over-heated zone and cover those area, which got heated above upper critical temperature range.

As in this area metal gets heated above upper-critical temperature range hence, carbon dissolves in iron and austenite microstructure forms. And after cooling rate is sufficiently high to avoid grain growth and forms fine-grain structure similar to normalized steel is formed.

**d. Transition Zone: -**

This zone gets heated bellow critical point. Hence complete re-crystallization does not take place but partial recrystallization takes place. Hence instead of a clear grain structure pattern a complex structure gets produce.

After this zone base-metal remains unaffected.

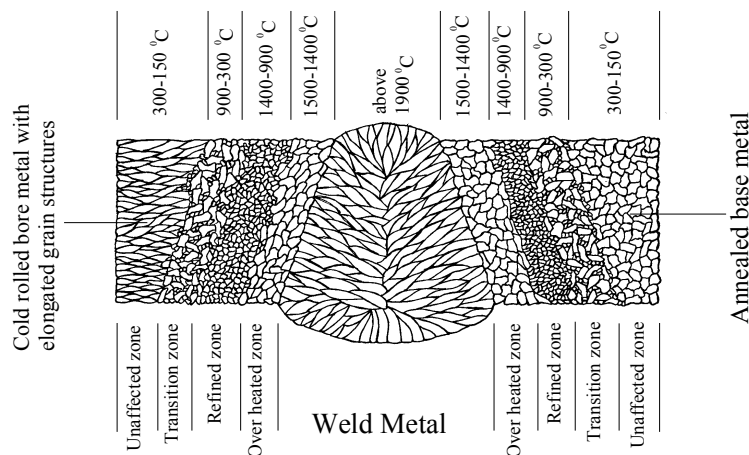

Figure No. 18.7.1

From the knowledge of ① Mechanism of grain growth, ② Effect of carbon on iron and ③ Effect of cooling rate on grain structure of iron. We realize that it is not only the welding rod and technique of welding affect the strength of a welding joint. But most important is composition of base-metal, core of welding rod, and preheating and controlled cooling rate of welded joint which governs the strength of welding joint. If due to any reason base metal has various alloying elements, which are difficult to weld, then special welding rod is to be used to get good welding strength, which we will study in chapter of selection of welding rod. And in case when cooling rate cannot be controlled and harden zone are bound to form, the welded structure are heat treated to reduce the residual stress set up during welding and to eliminate the hard zones.

The heat treatment we will study in chapter on hard treatment.

**18.8 Deformation and Distortion in Welding: -**

When heated, metals expands, and when cool down they contract. This is basic property of metal, which is main cause of deformation and distortion of a fabricated structure.

To understand it correctly let us discusses two examples.

Example – 1: - Welding of a slotted plate.

Sample piece of weld able type iron plate with a slot at center is ready for welding.

When a welding run is passed above the slot on one side. The base metal on topside of slot gets heated up, and tries to expand. This expansion is resisted by all the cooler area on lower side of slot. Heating reduce the yield strength of metal. Hence cooler areas are stronger then heated area hence, heated portion cannot deform the cooler portion. Hence mass of the metal, which is expanding due to heat, cannot expand, so they expand in thickness side and increase the thickness of plate.

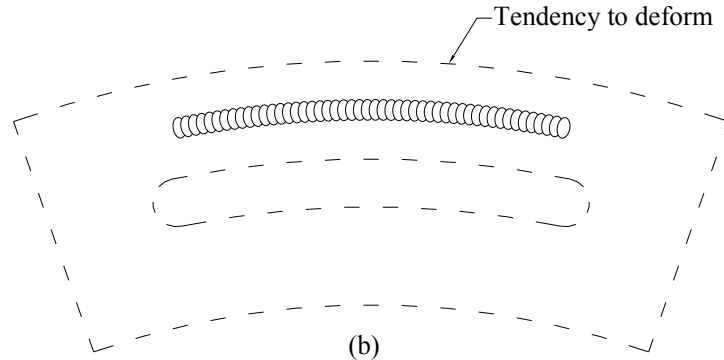
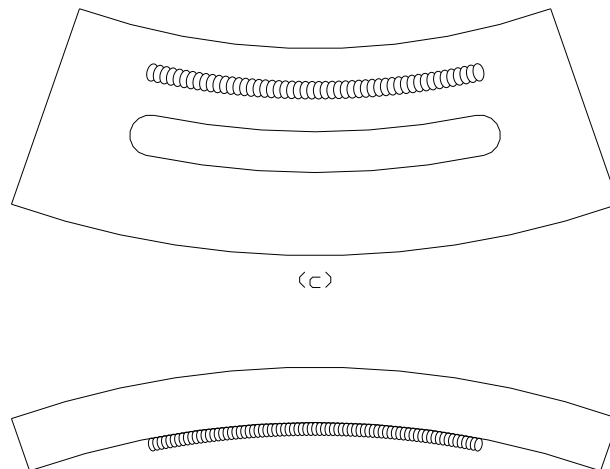

Figure No. 18.8 (a)

Now the welding run is start cooling. As temperature reduce strength increase. Reduction in temperature results in contraction of heated mass. Upper portion of slot, when contracts it pulls the lower portion of slot. Lower portion offer resistance as it resisted when upper heated portion tried to push it. But now contraction portion is much stronger due to reduction in temperature and increase in strength, it over come the resistance offered by lower portion, tensile stress developed in this portion, reaches the yield point and deformation takes place as shown in Fig No. 13.21

Same thing also occurs in thickness direction. Hence distortion is not in one direction but in two directions.



### The Effects of Distortion

Figure No. 18.8 (b)

CASE – 2: - In above example we studied effect of distortion due to welding on single base-metal. Now we will study the distortion when two base metals joint together.

Consider a single 'V' butt joint. When the root run is laid down. The weld deposit when in heated condition undergo expansion; but as base-metal are rigid, the welding deposit its self undergo plastic deformation and swells-out. When it starts cooling, its strength increases and pulls in the base-metal. Hence the direction of shrinkage is towards weld-deposit.

Now when second run is made. Initially the new deposits tries to push the two base-metal. Which is resisted by weld-deposit of first run. And when it cool down it pull the base-metal, which is again resisted by weld-

deposit of first run. But while contracting weld deposit of second run becomes strong due to increase in strength at low temperature hence it pulls the base-metal. Which results in distortion in angular direction.

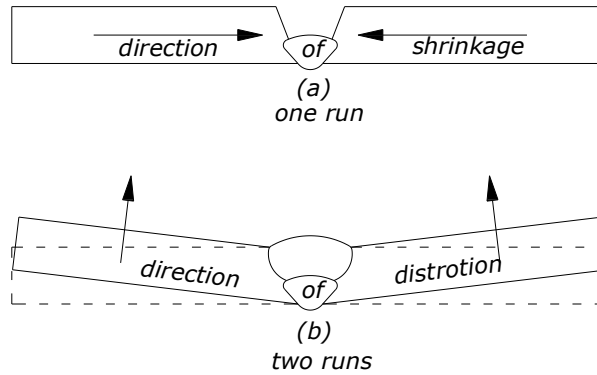

Angular Distortion

Figure No. 18.8 (c)

CASE-3: - When a base-metal is welded at its center, it also undergoes distortion in longitudinal and transverse direction as shown in following fig.

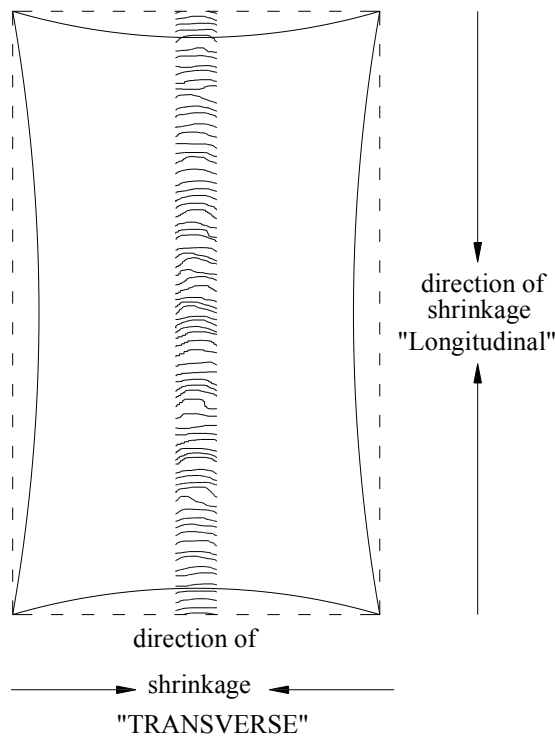

Longitudinal and Transverse Distortion

Figure No. 18.8 (d)

### HOT-CRACKING: -

We have already discussed the process of distortion in welded joint. To avoid distortion, the base metal are reinforced or supported externally to avoid distortion. In such cases some time crack-appear in weld- deposit, when it is still in heated condition, this defect is called **Hot-Cracking**.

Base-metal as well as core of welding rod contains impurities such as sulphur, nitrogen, high carbon, etc. which has low-freezing point that is they freezes after iron gets solidified. When molten metal of weld-deposit starts solidifying below 1500°C the dendrite forms, and grows to make grains. The impurities get collected on boundary of two grain, and produce a weak joint between two grain. At around 1000°C all mass of weld-deposit gets solidified and shrinkage starts. But as weld deposit has weak joint between grain boundaries.

Hence the pulling stress produces a fracture on grain boundary, which progress and become a big crack in weld-deposit. It may remain hidden bellow weld-metal and called **under-bead cracking** or appear on surface.

### 18.9 Control of Welding Distortion: -

In welding distortion is bound to happen, but following suggestion will help to reduce it.

- 1 **DO NOT OVER-WELD:** - Weld exactly amount required. More welding means more heating. Which results in more contraction and more deformation.
- 2 **USE AS FEW PASSES AS POSSIBLE:** - the more the number of passes, the more is resulting shrinkage, because shrinkage of each pass tends to cumulate, and hence the distortion. Use large size electrode with high deposit efficiency for welding.
- 3 **Balance two shrinkage force to minimum overall distortion as explain in following fig.**

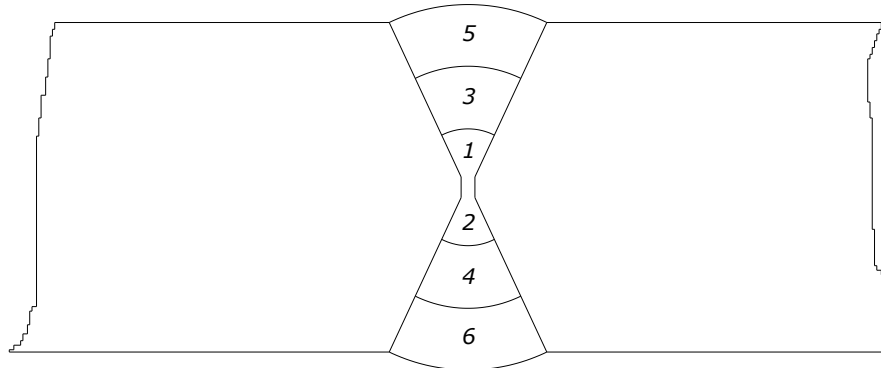

### Double Vee Preparation

Figure No. 18.9

- 4 **Pre-heat the base-metal** so that there is no localized heating and cooling which results in distortion and residual stress. Due to pre-heating, cooling rate of weld-deposit slows down, and it cools along with whole body hence no contractional force, which cause distortion.

- 5 **NEUTRALIZE SHRINKAGE FORCE DURING AND AFTER WELDING BY PENNING:** - Penning is an operation in which weld-deposit is hammered to make it thin or flat in hot condition to stop its shrinkage tendency.

In figure (13.22) weld-metal is pulling base-metal for an angular- distortion. When it is hammered, the tendency of pulling gets neutralized. Use blunt chisel if direct hammering is not possible.

- 6 **Use jigs and fixture or support to avoid distortion.** Before welding we can predict how the distortion will take place. To reduce or avoid it we can use external support or fixture till joint cooled down. But such procedure produces residual stress in base metal. Residual stress can be reduced by normalizing, or post-heating.

- 7 **Use back step and skip method of welding:** -

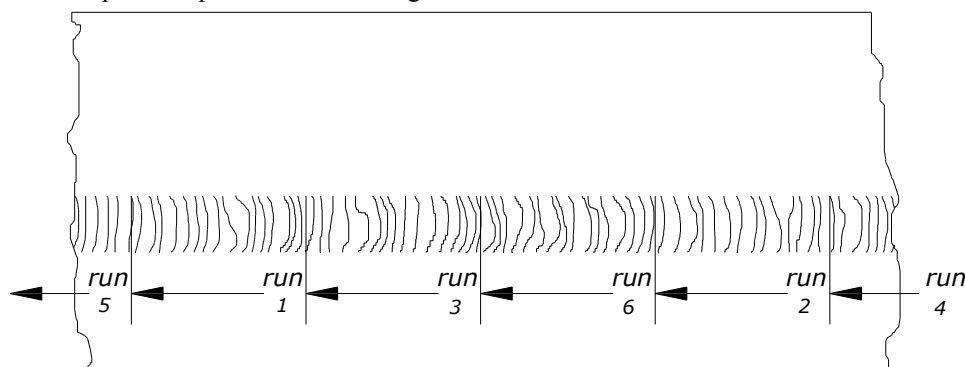

### Skip Welding

Figure No. 18.9 (a)

Overall welding progress from left to right, but each small run is made from right to left.

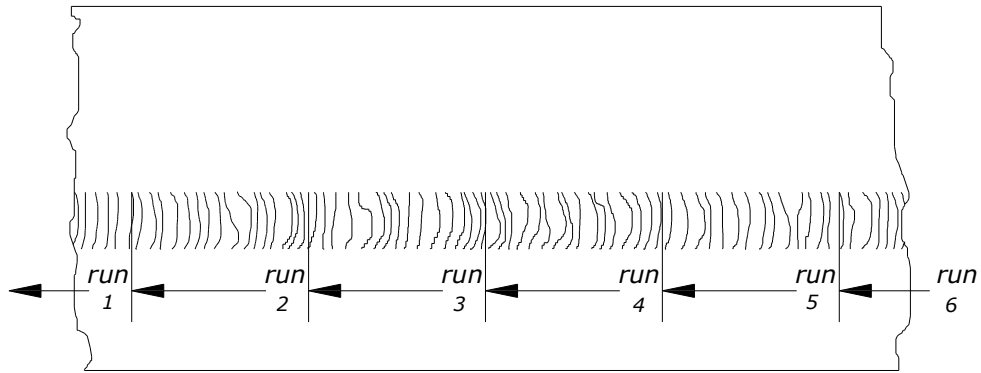

### Back Stepping

Figure No. 18.9 (b)

#### 18.10 Common Weld Defects and their Remedies: -

##### 18.10.1 Porosity: -

Porosity is caused by damp electrodes, rusty and dirty plates. High sulphur contains in plate, and sluggish welding.

**REMEDY:** - Bake electrode before welding, clean and grind surface before welding. Select suitable electrode to overcome effect of sulphur.

##### 18.10.2 Slag Inclusion: -

This can be on the surface or hidden, and caused by the dirty surfaces of the joint; Improper sequence and arrangement of subsequent welding passes. Inadequate cleaning after each pass. Using wrong grade of electrode, and using large size of electrode for narrow groove.

**Remedy:** - Clean surface thoroughly, after every pass clean slag completely, and hand grind it if required. Decide each pass of welding, while welding deep groove; ensure that there is always room and space to clean slag. Use correct grade and size of electrode.

##### 18.10.3 Lack of Fusion: -

It caused by incorrect joint preparation, and fit-up. Using too large or small electrode as compared to base-metal size. Too low current for given electrode size. Improper arrangement of passes.

**Remedy:** - Prepare joint correctly, use deep penetration type of electrode. Use correct current for selected electrode.

##### 18.10.4 Under Cutting: -

It is caused by too high current, wrong angle of welding of electrode, too fast welding speed.

**Remedy:** - Learn the caused by using too low current, too slow welding speed and due to improper angel of electrode.

##### 18.10.5 Cracking: -

This is the most severe type of defect which can hamper the performance and life of a hydraulic press drastically. Their possible cause and remedies are as follow.

- a) Welding will crack if base-metal is high in carbon or sulphur or hardening elements like MO, Cr, V, Ni, etc. Use hydrogen-controlled electrode for welding and pre-heat job before welding.
- b) Welding will also crack if weld-metal of electrode is not ductile enough, it may be too low in manganese or too high in carbon. Welding will also crack if electrodes are very damp. Use correct grade of electrode and bake if before use.

c) Welding will crack if the base-metal are not fitted correctly. At the root base metal must fuse correctly. If base-metal do not fuse, then cracking propagate from unfused joint of base-metal.

Improve fit-up, use deep penetration type electrode, use correct size of electrode as per gap, and pre-heating of job.

d) In high carbon steels and alloy steels, especially when the section is thick “Under bead cracks” are more pronounce at the junction between the weld metal and the base-metal. These are not visible initially but open out to the surface after some period. This can be avoided using ductile type electrode low in hydrogen and freshly dried in oven before use. Base-metal (joint area) is also adequately pre-heated.

#### **18.10.6 Hydrogen Cracking: -**

Under intense heat of arc, the water in form of moisture gets dissociated in oxygen and hydrogen. The iron at high temperature is in the form austenite which can dissolve high amount of hydrogen at high temperature, but solubility decrease with reduction in temperature.

Hence the dissolved hydrogen; starts separating form solid solution with drop in temperature and start the collecting in gaps, and fissres between the dendrites and grain boundary, and produces a weak joint. This joint open up in micro-sopic level a under contraction forces set up due to shrinkage. If grows and become a crack as cooling and contraction completes.

To avoid hydrogen cracking, avoid all source of moisture, use low-hydrogen type of electrode, and back it before use.

In this chapter we discussed only the commonly used type of welding process, that is “Welding by flux core welding rod”. So far we studied theoretical part of welding technology. We also should be aware of the welding electrode available in market by various manufacturers, coding of various grade of electrode. Flux used on electrode their function, and importance.

Core metal wire of many electrode’s are same. But their quality and grade differ due to the different type of flux coated on electrode wire. Following paragraph will give you idea about the material used in flux and their function and effect on welding.

#### **18.11 Electrode Coating Ingredients and their Functions: -**

##### **18.11.1 Slag Forming Ingredients: -**

Flux consists of silicates of sodium, potassium, magnesium, aluminum, iron oxide, china clay, mica, etc. These items produce a slag, which because of its light weight form a layer on the molten metal and protect the same from atmospheric contamination.

##### **18.11.2 Gas Shielding Ingredients: -**

Materials like cellulose, wood, wood flour, starch calcium carbonate etc. are added which form a protective gas shield around the electrode end, arc and weld pool.

##### **18.11.3 Deoxidizing Elements: -**

Elements like Ferro-manganese and Ferro-silicon refine the molten metal.

##### **18.11.4 Stabilizing Constituents: -**

Material like calcium carbonate, potassium silicate, titanates, magnesium silicate etc. are added to arc stability and ease of striking the arc.

##### **18.11.5 Alloying Elements: -**

Element like Ferro alloys of manganese molybdenum etc. are added to improve suitable properties and strength to the weld metal and to compensate the loss of some of the element, which vaporize while welding.

##### **18.11.6 Iron Powder: -**

This element, when added it improve arc behavior, bead appearance and mechanical properties it increase metal-deposition rate and arc travel speed. Slag is easily detachable. These electrodes because of slag fluidity are generally employed for welding.

#### **18.12 Coding of Mild Steel and Low Alloy Steels Electrodes: -**

##### **18.12.1 American System of Coding (AWS – ASTM): -**

E XXXX e.g. E 70 18



- vi) 6<sup>th</sup> Digit :- It indicate percentage elongation and impact value.
- vii) Last Digit :- It could be P, H, J, K and L.
- P = Indicate deep penetration electrode.
- H = Indicate hydrogen controlled electrode.
- J =Indicate electrode with iron power coating and metal recovery 110 – 130%.
- K =Is similar to J but metal recovery 130 – 150%.
- L =Is similar to J but above 150% recover of weld.

**In manufacturing hydraulic press Author recommend following grades of electrode.**

1. General purpose fabrication: -

Use E 6013 grade, **over-cord** or **over-cord-S** or equivalent grade of electrode for welding press-body up to 20mm thick plate and general fabrication.

2. Fluid Pipe Line Welding: -

Use E 6013 grade **over code-SS** or equivalent grade of electrode for welding steel seamless pipeline flanges etc.

3. Welding Thick Plate: - For welding thick plate use E7018 Grade low hydrogen electrode **supercito**, **supratherm** or equivalent electrode.

4. For welding thick plate first heat plates between 100 to 200 °C and bake the electrode and in heated condition weld them.

APPROXIMATE COMPARISON OF ELECTRODES OF VERIOUS MAKE					
TYPE	AWS CODING	ADVANI OERLIKON	D & H SECHRON	ESAB INDIA	ROYAL ARC
MILD STEEL	E 6010 E 6013 E 6013 E 6013 E 6013 E 6013	CITOJET OVERCORD OVERCORD – S OVERCORD – SS OVERCORD – S (SPL) COMET BLUE	----- NORMA MEDIO EXOBEL MEDIO – S FERROVITE	PIPEWELD 6010R ESAB FEROSPEED PLUS ESAB 28/ESAB VORDIAN ESAB VORTEX – 1  ESAB C2 3S	ROYAL – 6010 ROYAL – BOND ROYAL – S ROYAL – SS ROYAL – S (SPL) ROYAL – 724
LOW HYDROGEN	E 7016	UNIVERS	INDOTHERM	ESAB 56/ESAB FERROWELD - 1	ROYAL – 7016
LOW HYDROGEN IRON POWDER	E 7018 E 7018 – 1 E 7018 – A1	SUPERCITO – X PLUS TANACITO - Z PLUS MOLYCORD	SUPRATHERM SUPRATHERM (SPL) MOLY THERM	ESAB 36H/ESAB FERROWELD – 2 ESAB 36 H (SPL) OK 74.46	ROYAL THERM ROYAL THERM (SPL) ROYAL THERM MOLY
LOW ALLOY HIGH TENSILE	E 8018 – G E 9018 – G E 100 – M E 110 – M	TENACITO – 60 TENACITO – 70 TENACITO – 75 TENACITO – 80	SUPRATHERM NI (SPL) TENSAL ULTRATENSAL – M ULTRATENSAL – MH	OK 73.08 ----- ESAB – 118	ROYAL THERM (NI)SPL ROYAL 9018 ROYAL – 100M ROYAL – 110M
HARD FACING		CITORAIL – I CITORAIL – II CITORAIL – III CITORAIL – III (L.H.) CITORAIL – V CITOMANGAN	BOR – AR BOR – B BOR – C ----- D & H 630 H SMA	DUROID – 250 DUROID – 350 DUROID – 650 DUROID 650 B / ESAB 600 B ----- ESAB DUROMANGAN/MN (SPL)	ROYAL C – I ROYAL C – II ROYAL C – III ROYAL C – III (L.H.) ROYAL C – V ROYAL MANGAN
STAINLESS STEEL	E 308 – 16 E 347 – 16 E 308L – 16 E 316 – 16 E 318 – 16 E 316L – 16 E 310 – 16 E 317L – 16 E 309 – 16 E 309 Mo – 16 E 410 – 15 E 410 NiMoXX E 18.8 Mn B 20	SUPER INOX – 1A SUPER INOX – 1B SUPER INOX – 1C SUPER INOX – 2A SUPER INOX – 2B SUPER INOX – 2C INOX – CW SUPER INOX – 2D INOX – D2 INOX – D2 Mo CITOCROME – 13 CITOCROME 13/4 CITOCROMAX – ND	RUTOX – A RUTOX – A (STB) RUTOX – B RUTOX – Mo RUTOX – Mo (STB) RUTOX – D D & H – 310 16 RUTOX – E D & H 309L D & H 309 Mo D & H – 13Cr ----- SIA (RUTILE)	OK 61.50 / CHROME WELD R 316 OK 61.80 OK 61.30 OK 63.50 / CHORMWELD R 316 OK 63.8 OK 63.30 OK 67.13 ----- OK 67.60 OK 68.00 OK 68.10 ----- CHORMIWELD – G	ROYAL – 1A ROYAL – 1B ROYAL – 1C ROYAL – 2A ROYAL – 2B ROYAL – 2C ROYAL – CW ROYAL – 2b ROYAL – D2 ROYAL – D2Mo ROYAL CHROME – 13 ROYAL CHROME – 13/4 ROYAL 18 / 8 / 5
CAST IRON	EST ENIFE CI ENI CU – B ENI CI EDUNC	CITO CAST FERRONICRON SUPERFONTE SUPERNICRON BRONZE	D & H III CI D & H MONEL NFM -----	FERROWELD – 1 FERROLOID – 3 FERROLOID – 1 FERROLOID - 4	ROYAL CAST ROYAL CAST – FeNi ROYAL CAST CN ROYAL – N ROYAL BRONZE

5. For welding tested ASTM 106 grade seamless pipe of cylinder and endplug of flange etc. first pre-heat the cylinder, bake the welding rod, and then weld the root run with low hydrogen electrode such as **supercito** or **super-therm**. These electrodes spatter while using welding transformer hence welding rectifier will be more preferable. After welding root run full welding can be completed with same grade of electrode, or the last few run could be completed with **over-cord-SS** or Equivalent electrode.

6. For welding cylinder pipe of unknown grade or any two base metal of unknown grade, heat the base metal, and use **universe-W** grade electrode after baking it.

### 18.13. Welding of press body.

When press body is welded it with deform in following way.

1. Rectangular fabricated structure off four-column press

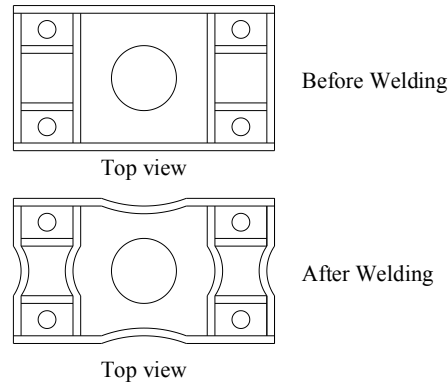

2. Long fabricated body.

Figure No. 18.13

We know the direction of deformation, before we start fabrication. Hence we provide support in such a way that it gets minimize. Supports removed after completion of fabrication. Maximum deformation occurs at the time of cooling of fabricated body. And some deformation continue for long period of time due to resident stress set in while fabrication. Hence if the accuracy of press-body is very important them press-body must –be annealed before removal of support. And if accuracy is not very important than also keep the support for maximum possible time, so that because of natural seasoning tendency to deform get reduced

### 18.14. Welding of Hydraulic Cylinder: -

Most critical welding in hydraulic press is a welding of end plug of hydraulic cylinder. Hence we will particularly study welding procedure of end-plug.

#### 18.14.1 Design of End-Plug And Welding Procedure: -

1. Design and decide the thickness of end-plug by equation.

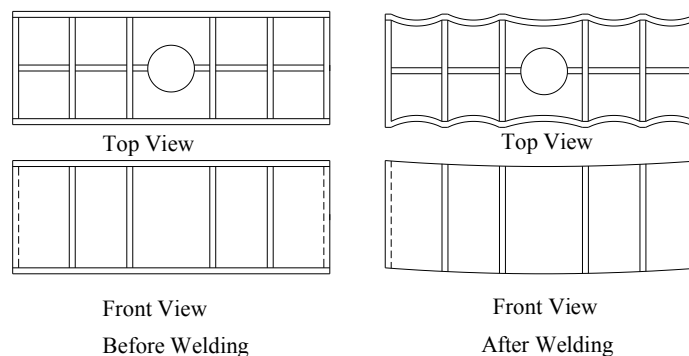

Figure No. 18.14.1

$$t = D \times 0.4 \text{ ("P/f)}$$

2. First end-plug is threaded and fitted in cylinder then welded. Calculate the number of thread required to takes the full load coming on end-plug.

Load on end-plug (W) = Area x Working Pressure = A x P

$W = D \times 3.14 \times p \times N \times fs$  (Number of thread required to withstand this load can be calculated as)

W = Load (kg.).

A = Area of cross-section of cylinder  $\pi D^2$  (cm<sup>2</sup>).

P = Working Pressure kg/cm<sup>2</sup>.

D = Pitch Circle diameter of end-plug / cylinder threading.

p = Pitch of thread.

N = Nos. of thread.

fs = shear stress of material.

Make threading and fit end-plug in cylinder.

3. For welding prepare the welding joint while machining thread.
4. Tighten the thread to maximum extend. So that end-plug does not have clearance for movement under pressure, thread takes all loads. Threads are for taking load and welding though can take load, but use them only for making joint leak proof.
5. Heat the joint and cover remaining portion of cylinder to avoid heat loss. Heat between 100°C to 200°C.
6. Use low hydrogen electrode for welding. Bake welding electrode for 2hr. at 150° to 200°C.
7. Run first weld as shown in following figure.

Do not weld continuously from one end to another, as it will develop the crack. Weld metal deposit pulls the end-plug to one side. Hence weld small line is opposite side to balance the pulling force. After one to two initial such run, then joint can be continuously welded.

8. In case of large cylinder use penning to over come pulling of end-plug on one side due to shrinkage in weld deposit. For penning, weld a small portion, clean the flux take a blunt chisel, and hammer the weld deposit with such a blow that it flattens the weld deposit. Do all this when weld deposit is still at sufficient high temperature. Repeat this till welding is completed.

9. After welding gets completed cover the whole cylinder, so that full cylinder gets slowly cooled. In no condition cool water or any thing fall on heated welding joint. Neither it should left in cool breeze for cooling down.

By slow cooling fine-grain structure will get produce, which are ductile and soft. Even if coare grain gets produced which has less strength, then also it does not matter, as load is taken by thread and not weld joint.

All cylinders expand when pressurized and contract on releasing pressure. If rate of cooling allowed to be vary fast then martensite grain structure will get produced in welded joint, which are very hard, brittle and welding will crack on cylinder pressurization.

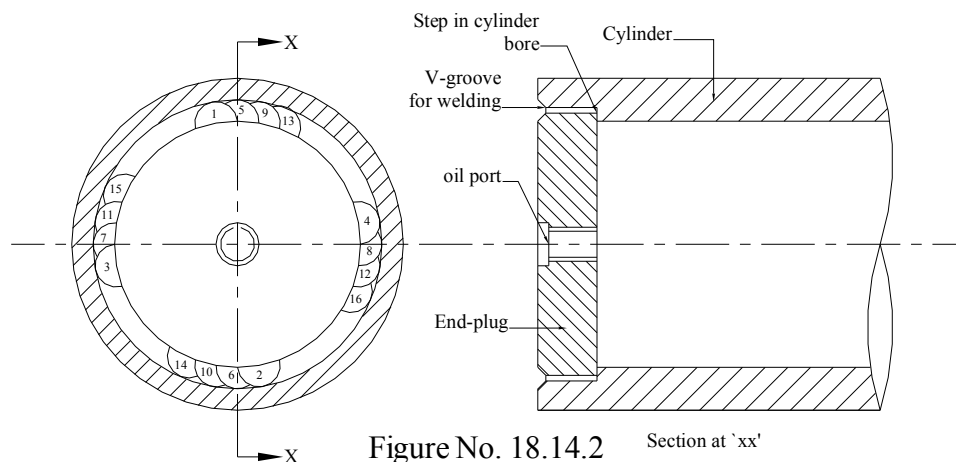

Figure No. 18.14.2 Section at 'xx'

10. Next day clean welded joint, and inspect for any crack developed. Test it and if it is found OK then said cylinder could be used for pressing.
11. In case welding cracks, then remove complete cracked weld –deposit before welding again, as welding done on cracked welding tends again. Test chemical composition of base metal, and accordingly select the welding rod. Universe-W electrode of Advani-Orlekon gives satisfactory result even in those mild steel base metal in which chemical composition are not as per standard.

## Chapter - 19

# Rolled Section

### 19.1. Introduction: -

In hydraulic press rolled I-beam and channel section are used for side column up to 300-Ton capacity press. Small presses used for general purpose, such as Bending, Straightening, Bearing fitting and removing etc. could be completely made from rolled I-section and channel etc. as shown in following figure. As it is one of the important construction material of hydraulic press, hence we will briefly study about it.

### 19.2. Reason for Selecting Rolled Section: -

Because of following reasons we give more preference to rolled section than fabricated section.

- a) In rolled section the material of construction is known and fixed as per ISI standard and could be selected as per requirement. For example for a weldable important load taking structure rolled section with IS-2062 grade material could be selected and used. For high stress and bolted construction IS-961 could be used. And for general purpose non-welded structure rolled section made from steel could be used.
- b) Rolled sections are made in various sizes. These sizes are internationally fixed and common. For each section all its parameter is known and data is always available in table form such as, its cross-section area, weight per unit length, moment of inertial at various axis, length, width, height, thickness etc.

Hence while calculation of strength we get all the data at our fingertip. So as per our requirement we can select most appropriate section serving our purpose.

- c) Rolled sections are already designed and standardised in such a way that they give maximum strength with minimum material used. Hence when we make a structure from rolled section then it always give more strength at less material used.

### 19.3. Material of Construction: -

Rolled sections are made from three types of material.

Grade (IS-2062) Mild Steel: -

When rolled section has to take load and structure is of weldable type then rolled section made from IS-2062 mild steel is used.

Grade (IS-961) Alloy Steel: -

When rolled section has to take high load at lower structural weight than IS-961 material is used. IS-961 is also of two types, weldable and non-weldable.

Grade (IS-1977-1962) Mild Steel: -

Rolled section made from these types of material used for general purpose and non-critical type of structure.

**19.4.** Details, Dimensions and Data about I-section, Channel-section and Angles are as follow.

## Chapter -20

# Fasteners

Most of the hydraulic cylinders and many parts of hydraulic presses are of bolted type. Generally four factor of safety are taken while designing and selecting the fasteners. That means at full capacity of cylinder we only reach up to 25% of permissible tensile strength capacity of fastener material. But it is observed in many cases that if cylinder is slightly over loaded bolt fails at much lower stress level than its permissible tensile stress. This is due to many factors such as.

- a. Wrong fastener material.
- b. Wrong design of fastener.
- c. Wrong heat treatment of fastener.

All good fasteners manufactures do their best to produce good quality fastener and inactually their fasteners are good. But small companies and cheaters who make duplicate fastener do all these mistakes. If you are purchasing a bolt of reputed make from open market like “Nagdevi Street” in Bombay, there are 50% chances that you will get duplicate bolts.

Because of this reason specifically we are presenting this chapter to make you aware of fasteners.

### 20.1 Types of Fasteners: -

There are hundreds of types of nuts, bolts and screws, it is beyond our scope to mention them here. In hydraulic press, we generally use, Elen and Hex bolts.

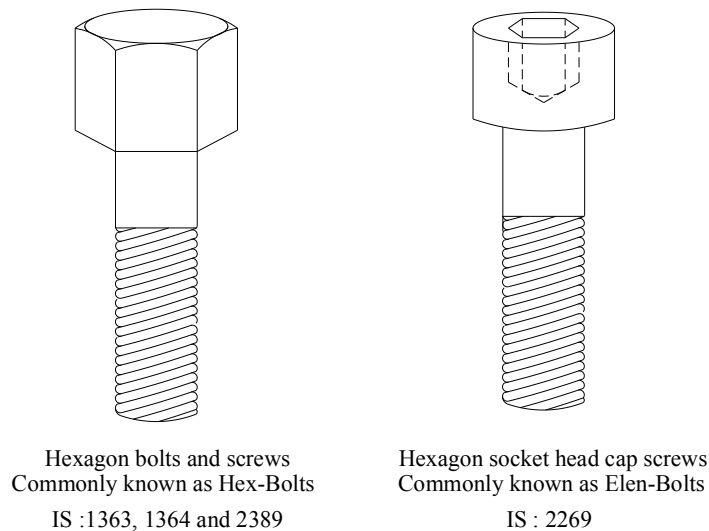

Figure No. 20.1

### 20.2 System of Designation: -

A bolt is designated by nine parameters. We will describe them with an example as follow.

**Hexagonal head, bolt, M20x75x1.5 NL, IS:1364 – S – 4.6**

1            2            3            4            5            6            7            8            9

This designation has nine parameters and each parameter describes following characteristic or specification.

Parameter No.1 = It indicate the type of head. It may be hexagonal head, hexagonal socket head cap, counter sunk, grub screw type and many more types. In present example is it is hexagonal head bolt.

Parameter No.2 = It indicates the type of fastener. It may be bolt, screw, nut, grub screw etc.

Parameter No.3 = M20 indicates it is bolt with ISO metric threads with 20mm diameter.

Parameter No.4 = 75 indicates that it has 75mm length.

Parameter No.5 = 1.5 indicates that it has special thread with 1.5mm pitch. For standard thread it is omitted.

Parameter No.6 = NL indicates the type of Nut. When nut is not used then it is omitted.

Parameter No.7 = IS-1364 indicates the standard by which bolt manufactured, it may be IS:2389 or IS: 2269, IS:6761 and many more as per the requirement.

Parameter No.8 = It indicates the type of grade of surface finish P, S, B, in present example it is S that is precision type which means good surface finish on all surface and thread, except point.

Parameter No.9 = It indicates the property of class. First digit is minimum tensile strength and next digit Ratio of minimum yield stress to minimum tensile strength. 4.6 means, it has 40 kgf/mm<sup>2</sup> as minimum tensile stress and 0.6 as ratio.

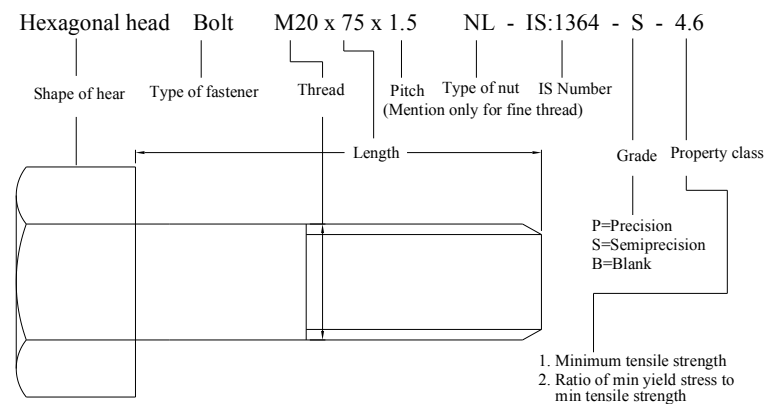

Figure No. 20.2

### 20.3 Material of Bolts: -

Bolts and nuts are made either from plain mild-steel, brass, stainless steel and alloy steel etc. In alloy steel bolts are generally made from EN-8, EN-9, EN-19, EN-24 etc. In hydraulic press we generally use fasteners made from M.S. or alloy steel.

### 20.4 Heat Treatment of Bolts: -

General purpose bolts and nuts made from mild-steel are not heat-treated. While bolts made from alloy steel are harden and tempered.

### 20.5 Strength of Bolts: -

As bolts are made from M.S., EN-8, EN-9, EN-19 and EN-24. Hence their strength depends on material used and the heat treatment. For standardization Indian institute for standardization has fixed many grades of bolt as per their strength, these are 4.6, 4.8, 6.6, 8.8, 10.9 and 12.9. The logic behind the grade numbers is as follows.

The first digit of the symbol indicates 1/10<sup>th</sup> of the minimum tensile strength. While the second digit indicates the ratio between minimum yield stress and the minimum tensile strength.

For example 4.6 means it has 40kg/mm<sup>2</sup> as minimum tensile strength, and 0.6 as ratio minimum yield stress and minimum tensile stress. Hence we can calculate 24kg/mm<sup>2</sup> as minimum yield stress

$$\frac{\text{Min. Yield Stress}}{\text{Min. Tensile Stress}} = 0.6 = \frac{24}{40} = \text{(calculated)} \quad \text{(known)}$$

### Mechanical Property of Threaded Fasteners

(for details refer IS-1367-1967)  
for Externally Threaded Bolts

Property			Property Class					
			4.6	4.8	6.6	8.8	10.9	12.9
Tensile strength Kgf/mm <sup>2</sup>	Min.		40	40	60	80	100	120
	Max.		55	55	80	100	120	140
Hardness	Brinell	Min.	110	110	170	225	280	330
		Max.	170	170	245	300	365	425
	Rockwell HRC	Min.	Not heat treated	Not heat treated	Not heat treated	18	27	34
		Max.				31	38	44
Yield stress kgf/mm <sup>2</sup>		Min.	24	32	36	-	-	-
Proof stress kgf/mm <sup>2</sup>			22.6	29.1	33.9	58.2	79.2	95
Elongation %		Min.	25	14	16	12	9	8
Impact strength		Min.	-	-	-	6	4	3
Max. Permissible stress assumed for calculation kgf/mm <sup>2</sup>			7	9	12.5	20	25	30
For dynamic loading permissible stress should be further reduced by approximately 66%.								

### For internally threaded Nuts

Property			Property class			
			4	6	8	12
For use with bolts of property class			4.6 4.8	6.6	8.8	12.9
Proof load stress kgf/mm <sup>2</sup>			40	60	80	120
Hardness	Brinell	HB max.	302	302	302	353
	Rockwell	HRC max.	30	30	30	36

Grade number means it is 1/10 of proof load stress nut of higher grade could be used with bolt of lower grade but not vice-versa.

Standard making authority has graded fasteners as per strength and not material used for manufacturing. Whatever material manufacturer uses, he has to ensure that final strength of fasteners should be as per grade.

**Tightening Torque (kgf.m)**

Grades	Sizes								
	M6	M8	M8x1	M10	M10x1.25	M12	M12x1.25	M14	M14x1.5
<b>4.6</b>	0.17	0.4	0.42	0.8	0.83	1.38	1.48	2.2	2.36
<b>6.6</b>	0.29	0.71	0.76	1.4	1.48	2.5	2.64	3.92	4.2
<b>8.8</b>	0.47	1.15	1.2	2.25	2.36	3.94	4.2	6.25	6.7

Grades	Sizes								
	M16	M16x1.5	M18	M18x1.5	M20	M20x1.5	M22	M22x1.5	M24
<b>4.6</b>	3.4	3.6	4.7	5.2	6.6	7.25	8.95	9.7	11.5
<b>6.6</b>	6.1	6.4	8.35	9.3	11.8	13	-	-	-
<b>8.8</b>	9.7	10.2	13.3	14.8	18.9	20.7	25.6	27.8	32.8

Grades	Sizes								
	M24x2	M27	M27x2	M30	M30x2	M33	M33x2	M36	M36x3
<b>4.6</b>	12.3	16.7	17.8	22.8	24.7	30.6	33.2	39.5	42
<b>6.6</b>	-	-	-	-	-	-	-	-	-
<b>8.8</b>	35	47.7	50.8	65	70.5	88	95	113	119

**Surface finish**

Fastener Grade	Surface		Surface finish symbol
	Bolt	Nut	
P	All surfaces and threads except points	All surface and threads	▼▼
	Point of bolt	Minor dia of thread	~
S	Thread, shank and bearing face	Thread and bearing face	▼▼
	All other faces	Flats and minor dia of thread	~
B	Flank and minor dia of thread	Flank and major dia of thread	▼▼
	Major dia of thread	Minor dia of thread	~
	All other faces	All other faces	~

**20.6 S.S. Bolt: -**

In chemical plant we use Stainless steel bolts. The details and requirement of such fasteners are as follow.

## a) Dimension Control: -

Dimensions of screws are controlled as per IS:2269 and Hexagonal socket head cup screw is controlled by IS:1367 standard.

Thread confirms to IS:4218 tolerance grade-6g-ISO metric screw thread.

## b) Mechanical Properties: -

The stainless steel bolt material should have following mechanical properties.

Ultimate Tensile Stress : 52.5 kg/mm<sup>2</sup> (min.)

Yield Strength (0.2% offset) : 21 kg/mm<sup>2</sup> (min.)

Percentage Elongation : 30% (min.)

Percentage Reduction : 50% (min.)

## c) Chemical Composition: -

Percentage of various elements in stainless steel is as follow.

Carbon	: 0.08 (max.)
Manganese	: 2.00 (max.)
Phosphorous	: 0.045 (max.)
Sulphur	: 0.030 (max.)
Silicon	: 1.00 (max.)
Nickel	: 10.00 to 14.00
Chromium	: 16.00 to 18.00
Molybdenum	: 2.00 to 3.00

d) Material: -

The material property and chemical composition of stainless steel is already described above. When American standard is considered, the material of AISI grade 316 in carbide solution treated condition meeting the requirement of ASTM-A-193 B8M is used.

### 20.7 Failure of Fasteners: -

There are many factors because of which fastener fails, few of which are as follow.

a. Incorrect Heat-Treatment: -

If high tensile bolts only hardened and not tempered then it remains brittle and fails at much lower stress, duplicate bolt manufactures generally do not temper to save manufacturing cost, hence bolt fail at much lower stress level or impact load.

b. Incorrect Design: -

If high tensile bolts are selected and fitted in mild steel body. If the corresponding threading in M.S. body is not increased accordingly, then bolt will not fail but threads in M.S. body will shear out. As ultimate tensile and shear of M.S. is lower than high tensile bolt. This also happens when lower grade of nut used with high grade of bolt.

c. Incorrect Manufacturing Technique: -

Elen bolts are made by forging on bolt forging machine which is called header. From a round coil of iron bar it continuously produces bolt. Making groove for elen key it punches groove in solid head. If depth of this groove is more, then elen bolt always fails at bottom of groove as indicated below.

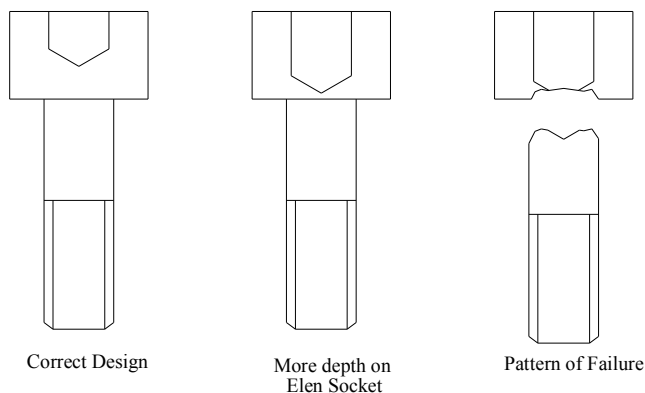

Figure No. 20.7

Small companies and duplicate bolt manufacturers do not purchase costly forging “Header” but use many small machine to make bolts. To make elen bolt, first drill the hole in head of bolt and then they punch it to make socket for elen key. To keep the correct depth of socket for elen key they over-drill the head. As some material in next operation of forging for making hex-socket for elen key also get deposited in bottom of drill. Such bolt always breaks at much lower stress level.

Hence always design fastener carefully, select right grade of bolts and purchase it from right source, otherwise your well designed and precisely made machine will fail at much lower stress at bolted joint.

### Pipe Thread (BSP)

Size inches	TPI	Pitch inches	Depth inches	Major dia inches	Minor dia inches	Drill Inches/mm	Alternate Inches/mm
1/8	28	0.0357	0.0229	0.383	0.3372	8.8	11/32
¼	19	0.0526	0.0337	0.5180	0.4506	11.8	11.7
3/8	19	0.05263	0.0337	0.6560	0.5886	15.25	19/32
½	14	0.0143	0.0457	0.8250	0.7336	¾	19
5/8	14	0.07143	0.0457	0.9020	0.8108	53/64	21
¾	14	0.07143	0.0457	1.041	0.9496	24.5	24.25
1	11	0.07143	0.0582	1.309	1.1926	30.75	1 13/64
7/8	14	0.09091	0.0457	1.189	1.0976	28.25	1 7/64
1 ¼	11	0.07143	0.0582	1.65	1.5336	39.58	1 35/64
1 ½	11	0.09091	0.0582	1.8826	1.7656	1 25/32	45
1 ¾	11	0.09091	0.0582	2.116	1.9996	51	--
2	11	0.09191	0.0582	2.347	2.23	2 ¼	57

### British Standard with worth thread - BSW

Thread Size Inches	Bolt and nut						Nut			Washer		Ellen bolt	
	Major dia mm	Minor dia mm	Tensile stress area mm <sup>2</sup>	Thread per inch	Pitch mm	Thick-ness of head mm	Thick-ness mm	Width across flats mm	Width across corners mm	Outside dia mm	Thick-ness mm		
¼	6.35	4.72	0.175	20	1.27	5	5.5	11	12.7	14	1.5		
5/16	7.94	6.13	0.295	18	1.41	6	6.5	14	16.2	18	2		
3/8	9.53	7.49	0.441	16	1.59	7	8	17	19.6	22	2.5		
1/2	12.70	9.99	0.784	12	2.12	9	11	22	25.4	28	3		
5/8	15.88	12.92	1.311	11	2.31	11	13	27	31.2	34	3		
3/4	19.05	15.80	1.960	10	2.54	13	16	32	36.9	40	4		
7/8	22.23	18.61	2.720	9	2.82	16	18	36	41.6	45	4		
1	25.40	21.34	3.575	8	3.18	18	20	41	47.3	52	5		
1 1/8	28.58	23.93	4.497	7	3.63	20	22	46	53.1	58	5		
1 ¼	31.75	27.10	5.770	7	3.63	22	25	50	57.7	62	5		
1 3/8	34.93	29.51	6.837	6	4.23	24	28	55	63.5	68	6		
1 ½	38.10	32.68	8.388	6	4.23	27	30	60	69.3	75	6		
1 5/8	41.28	34.77	9.495	5	5.08	30	32	65	75.0	80	7		
1 ¾	44.45	37.95	11.310	5	5.08	32	35	70	80.8	85	7		
2	50.80	43.57	14.912	4 ½	5.65	36	40	80	92.4	98	8		
2 ¼	57.15	49.02	18.873	4	6.35	40	45	85	98.2	105	9		
2 ½	63.50	55.37	24.079	4	6.35	45	50	95	109.7	120	9		
2 ¾	69.85	60.56	28.804	3 ½	7.26	50	55	105	121.3	130	10		
3	76.20	66.91	35.161	3 ½	7.26	54	60	110	127.1	135	10		
3 ¼	82.55	72.54	41.333	3 ¼	7.82	58	65	120	138.6	150	12		
3 ½	88.90	78.89	48.885	3 ¼	7.82	62	70	130	150.2	160	12		
3 ¾	95.25	84.41	55.959	3	8.47	67	75	135	155.9	165	12		
4	101.60	90.76	64.697	3	8.47	70	80	145	167.5	180	14		
4 ¼	107.95	96.64	73.349	2 7/8	8.84	75	85	155	179.0	190	14		
4 ½	114.30	102.99	83.307	2 7/8	8.84	80	90	165	190.5	205	14		
4 ¾	120.66	108.83	93.014	2 ¾	9.24	84	95	175	202.1	215	16		
5	127.01	115.18	104.185	2 ¾	9.24	90	100	180	207.9	220	16		
5 ¼	133.36	120.96	114.922	2 5/8	9.68	94	105	190	219.5	230	16		
5 ½	139.71	127.31	127.304	2 5/8	9.68	98	110	200	231.0	245	18		
5 ¾	146.06	133.04	139.022	2 ½	10.16	102	115	210	242.6	255	18		
6	152.41	139.39	152.608	2 ½	10.16	106	120	220	254.1	270	18		

<b>ISO Metric Screw Threads</b>											
Design profiles of internal and external threads											
Thread size mm	Bolt				Nut			Washer		Ellen bolt	
	Minor dia mm	Tensile stress area mm <sup>2</sup>	Pitch mm	Thick-ness of head mm	Thick-ness of nut mm	Width across flats mm	Width across corners mm	Outside dia mm	Thick- ness mm	Head Dia	Head Thick
M1.6	1.171	1.27	0.35	1.1	1.3	3.2	3.48	4	0.3		
M2	1.509	2.07	0.4	1.4	1.6	4	4.38	5	0.3		
M2.5	1.948	3.39	0.45	1.7	2	5	5.51	6.5	0.5		
M3	2.387	5.03	0.5	2	2.4	5.5	6.08	7	0.5	5.5	3
M4	3.141	8.78	0.7	2.8	3.2	7	7.74	9	0.8	7	4
M5	4.018	14.2	0.8	3.5	4	8	8.87	10	1.0	8.5	5
M6	4.773	20.1	1	4.0	5	10	11.05	12.5	1.6	10	6
M8	6.466	36.6	1.25	5.5	6.5	13	14.38	17	1.6	13	8
M10	8.160	58.0	1.5	7.0	8	17	18.90	21	2	16	10
M12	9.853	84.3	1.75	8.0	10	19	21.10	24	2.5	18	12
M16	13.546	157	2	10	13	24	26.75	30	3	24	16
M20	16.933	245	2.5	13	16	30	33.53	37	3	30	20
M24	20.319	353	3	15	19	36	39.98	44	4	36	24
M30	25.706	561	3.5	19	24	46	51.28	56	4	45	30
M36	31.092	817	4	23	29	55	61.31	66	5	54	36

**Chapter -21****Surface Protective Coating**

In hydraulic press, surface of various parts are coated for.

- a) To increase the wear resistance against friction and rubbing.
- b) To increase the resistance against corrosion.
- c) For better outlook.

Piston-rod, guide-rod, columns are hard-chrome plated to increase the surface hardness and increase wear resistance.

Small components of press-body, parts of valves and Knobs etc. are blakodised to increase corrosion resistance and better outlook.

Many components of press body are galvanized to increase corrosion resistance. Control panel, oil tank and many component of press-body are painted or powder coated for better outlook, corrosion resistance and long life.

For better understanding of said surface protective coating we describe these coating process shortly as follow.

**21.1 Chromium Plating: -**

Pure chromium metal is coated on various parts of hydraulic press by electrolysis process to increase wear resistance, to protect against corrosion and for better outlook.

Chromium plating is of two types.

1. Flash Chrome Plating.
2. Hard Chrome Plating.

**21.1.1 Flash Chrome Plating: -**

In flash chrome plating, a very thin lays of chromium is coated on surface. This may vary from 0.005 to 0.015mm. Purpose of flash chrome plating is for better esthetic outlook and corrosion resistance. As very thin layer of chromium is plated, hence grinding after plating is generally not performed to control final size.

**21.1.2 Hard Chrome Plating: -**

In hard chrome plating minimum 0.025mm layer of chromium is plated on article. Maximum thickness of coating depends on requirement, and even 1mm coating also be applied. As thickness increases cost also increases. The optimum cost economy and better wear resistance we get at 0.05 to 0.06mm plating.

When article is plated, at its edges more metal is deposited, which is called “Edge-Build-Up”. To precisely control size of article slightly more metal is deposited and then article is grounded to get correct dimension.

Press columns, Guide-bar, Piston-rod, Ram etc. are turned, then ground, then chrome plated and again ground to get correct size as per tolerance limit, and uniform dimension through out its length and then buffed to get mirror like finish.

We get 55RC hardness at 0.025mm plating 58RC at 0.05 plating. And after that what ever may be the plating thickness, hardness could not be increase more than 59RC.

**Baking: -**

The articles, which are hardened or cold-worked may be harmfully embrittled by hydrogen absorption during chromium plating. The hydrogen may be removed and the physical and mechanical properties of article restored by baking the component, immediately within one hour after plating in an oven maintained at a uniform temperature of 190°C to 200°C for at least 3 hrs. The time of baking depends on cross section of article, thickness of plating and severity of embrittlement.

**21.2 Chromium Plating Procedure: -**

Chromium plating procedure consist of cleaning and plating. As quality of plating depends on cleanliness of surface, hence many operations performed to ensure perfect clean surface of article. After plating if baking required then only articles are backed, otherwise it is not performed.

We described a common chromium plating procedure as follow.

1. **Cleaning:** - Article may be cleaned by vapour degreasing, organic solvent, emulsion cleaners, spray cleaners or by coated buffing wheels.
2. **Racking:** - As chrome-plating is an electrolytic process, hence position of article with anode and its electrical contact is very important. Before plating articles are carefully racked with clear and tight contact with electric supply.
3. **Electrolytic Alkaline Cleaning:** - After cleaning physically and racking, component may be electrolytically cleared. The electrolyte and current parameter for electrolytic alkaline cleaning is as follow.

Sodium Carbonate . ( $\text{Na}_2\text{CO}_3$ )	= 30 to 40 gm/liter of water.
Trisodium Phosphate (hydrate) ( $\text{Na}_3\text{PO}_4 \cdot 12\text{H}_2\text{O}$ )	= 15 to 30 gm/liter of water.
Sodium Hydroxide (NaOH)	= 7.5 to 15 gm/liter of water.
Voltage	= 6 volts.
Current density	= 3.2 to 5.4 Amps/cm <sup>2</sup> .
Cathodic cleaning followed by	= 1 to 2 min.
Anodic cleaning	= 15 to 30sec.

Notes: -

- 1) Alloy Steel, high strength or hardened steel components (over 40RC) should not be cleaned cathodically as serve hydrogen embrittlement may result.
- 2) High nickel steel components should not be cleaned anodically as this may develop an oxide film and reduce the adhesion of the chromium. However cathodic alkaline cleaning may be carried out for these steel components.

**Rinsing: -**

To remove all the residual alkaline chemical, the components are rinsed in boiling water.

**Etching: -**

Components are placed in chromium plating bath, electrical contacts are made, article to be plated is made cathode and a lead sheet as anode. Then just before plating electrical switch is reversed to make article anode lead sheet as cathode for five minutes.

**Chromium Plating: -**

After anodic etching in chromium plating both, the components are again connected to negative bus-bar electrically by reversing switch, and made it cathode. Following operating conditions are recommended for chromium plating.

Chromic Acid ( $\text{CrO}_3$ ) = 250 to 400 gm/litrs of water.

Sulphure ( $\text{SO}_4$ ) radical the Sulphate radical is generally added as 94 to 96 as weight percent of sulphoric acid

( $\text{H}_2\text{SO}_4$ ) =  $\text{CrO}_3 : \text{SO}_4$  = 100 : 1

Operating temperature =  $40^\circ\text{C} : 60^\circ\text{C}$

Current density = 7.6 to 50 Amp/ $\text{cm}^2$ .

After plating article may be ground to control the dimension and buffed to get shining mirror like finish. If baking required then article should be baked within one hour on plating.

**21.3 Standards for Chrome Plating: -**

ASTM – B – 254 = This standard recommends the practice for preparation of Electroplating.

ASTM – B – 177 = This standard recommends the practice for chromium plating on steel for engineering use.

**21.4 Thickness Measurement: -**

The thickness of plating could be measured by micro-meter or caliper or by microscopic meter. For large size component such as Press column, Ram, Piston rod, etc. size is taken before plating and after that difference is shown in the plating thickness.

In large quantity of small component in which few sample could be spared for destructive testing are cut into pieces. Polished and etched as we do in metallurgical laboratories and then observed in microscope. The thickness may be measured with an accurately calibrated filar ocular micrometer, or the image may be measured with an accurate ruler on a ground glass focusing plane of a metallographic microscope.

**21.5 Adhesive Testing: -**

The layers of chromium should not pill-off. For adhesive test of plating we also chrome plate a sample stripe of 100mm length, 25mm thick and 1mm thick.

On completion of plating we bend strip at 180 degree. When sample piece break in to two, then the chromium layer on broken edge should not come out when scraped with a sharp tool.

**21.6 GALVANISING: -**

Galvanising is again similar to chromium plating procedure. In this process zinc is deposited on components to be plated.

Article to be plated is made Cathode, pure zinc metal is made Anode and hydrochloric acid is used as electrolyte. Approximately 8 to 10 micron is deposited on the surface, and this process takes approximately 30 minutes time.

Instead of electrolysis process, zinc is also deposited by Hot-Dip galvanizing process, in which after cleaning job thoroughly dipped in hot zinc bath, then removed. By this dipping in hot zinc, zinc form a thin layer of alloy with base metal at interface between base metal and coating.

Zinc form more protective coating on Iron than Tin and other metal. And gives best protection against corrosion.

## **21.7 BLACKENING: -**

(Black finishing on Iron and Steel, it is also called blackodising)

In this process iron articles are heated in an alkaline solution, because of which it gets a black finish on its surface. This is due to chemical reaction. By this process dimension do not change. But if blacking process carried out for long time then dimension may increase by 0.025mm to 0.05mm.

By this process black finish gives good aesthetic appearance, it is also corrosion resistance up to certain extent.

Said chemical is available with its commercial name such as “Ranuk Hylak salt”. This salt in ratio of 750gm salt in one liter water, heated between 140-144 °C and then article is dip for 15 to 45 minute for getting black finishing on it.

By this process iron and steel gets a good shining black finish on its surface, which is also corrosion resistance up to certain extent. Many components of hydraulic valves are blakodised.

## **21.8 PAINTING: -**

### **21.8.1 Introduction: -**

A hydraulic press may remain in operation and give good service for more than 20-25 year. The places where oil and grease applied for lubrication remain protected again corrosion, but majority of surface remain susceptible to corrosion.

Paints are applied for all such susceptible areas, but if surface is not properly conditioned before painting and correct type of painting procedure are not followed and paints are not selected correctly then even after spending money on painting, paint will start pilling-off within six month to one year time. And once paints pill-off from surface corrosion starts.

Hence we briefly describe the surface preparation and painting procedure in this chapter.

### **21.8.2 Surface Preparation: -**

- a) All the surface to be painted should be thoroughly cleaned. Cleaning may be done by hand-grinding, sand-blasting, de-greasing, picking (de-rusting) etc. After cleaning white metal finish of iron should be visible.

- b) Automotive industries have well automised painting shop. After thoroughly cleaning surface they dip sheet metal in a phosphate compound. Which chemically reacts with white metallic surface of steel and forms a gray colour compound on it. This phosphated surface primer makes better bonding with white metal. And paint gets more resistance against corrosion and remain for longer period on surface. For hydraulic press we do not do it. But if some one want to do it, then such chemical is available in market.

### 21.8.3 Application of Primer: -

If paints are directly applied to such clean metallic surface, then they do not stick to surface, and will pill-off from surface in a thin layer form. Paint is also poor corrosion resistance.

For making good bonding between paint and metallic surface and increase corrosion resistance primers are applied before painting.

### 21.8.4 Primer: -

Primer generally consist of:

- a) Resin (10 to 15%).
- b) Chemical compound such as Iron-oxide, Zinc-chromed etc. (10 to 15%).
- c) Filler such as China clay, Talcum powder, Whiting (40 to 45%).
- d) Drier such as Manganese octet, Cobalt octet etc.
- e) Base solution such as mineral oil, turpentine.

Resin makes bonding with metallic surface and chemical compound such as Iron-oxide and zinc-chromed makes a thin film on surface which do not allow oxygen to pass through it and react with base-metal, hence give corrosion resistance properly.

### 21.8.5 Type of Primer: -

Primers are of three types: -

- a) Epoxy bases primer.
  - b) Zinc chromate primer.
  - c) Red-oxide primer.
- a) Epoxy Based Primer: -

In this type of primer epoxy chemical is used, which has best resistance against corrosion and chemical, as compared to other type of primer. In this type of primer hardener is separately packed and they are mixed just before painting.

- b) Zinc-Chromate: -

In this type of primer main corrosion resistance compound is zinc-chromate. This gives better corrosion resistance than iron-oxide based primer. And gives best results and very long life to paint if applied on clear white metallic surface.

- c) Red-Oxide-Primer: -

This is most commonly used primer in industry. In this type of primer iron-oxide is used which gives corrosion resistance property. As iron-oxide is reddish in colour hence this type of primer are commonly know as **Red-oxide**.

### 21.8.6 Application of Paint: -

After applying primer, Lambi or N.C. putty are applied to fill the uneven surface. After they dry, they are rubbed with sand paper to get smooth surface. In such rubbing process some time primer also gets removed at some places. Hence again a coat of primer is applied before applying the final paint.

Primer sticks to metal surface due to resin in it, when paint applied on primer it fills in porosity of primer as well as lambi and putty applied to it. Hence it gets good bonding with primer. And do not pill-off, as it happens when paint directly applied on metallic surface.

After first coat of paint, dry-out, over all quality of paint is inspected. If required again minor touch-up with N.C. putty is done, then again second coat of paint is applied. This completes the painting process.

Generally primers as well as paints are applied two coat each. And preferable thickness of primer as well as paint is between 90 to 100 micron. Hence total 200 micron coating thickness we get on surface.

### **21.8.7 Types of Decorative Paint: -**

There are so many types of paint but generally two types of paints are used for machinery.

- a) Epoxy paint.
- b) Decorative paint.

#### **a) Epoxy Paint: -**

Epoxy paint is best with respect to resistance against corrosion and service life. Epoxy is main constituent in paint, it is mixed with hardener just before application of painting and then applied on surface.

#### **b) Decorative Paints: -**

Decorative paints are available in many commercial grade, such as oil-paint, which has glossy finish and fully dry in more than 12 hours time. Fast-drying paint, which dry-out in one hours time. Hammer tone paints, which are similar to oil paint but they have special dented texture. When surfaces are uneven and it is not economical to finish it by applying lambi and putty etc. in such condition if hammer tone paint applied then, those defect on surface will not be visible.

We apply total four coats of primer and paint and also a layer of lambi or putty. Precaution should be taken that when one coat fully dry-out then only second coat is applied. As well as when putty fully get harden then only rubbed and applied with primer to get better quality of paint and life.

**Chapter - 22****GRAPHICAL SYMBOLS FOR FLUID POWER SYSTEMS****1. Scope :-**

Defines the principles of the use of symbol and specifies the symbol to be used in diagrams for fluid power systems.

The use of these symbols does not preclude the use of other symbols commonly used for pipe work in other technical fields.

**2 General Symbol :-****2.0 Symbols Rule**

**2.0.1** The symbols show connections, flow paths and the functions of the components represented. They do not indicate construction or any physical relationship such as location of ports, directions of shifting of spool or the position of actuators; nor do they indicate values, such as pressure, flow rate or other component setting.

**2.0.2** When a component performs more than one function, basic symbols may be combined and arranged to show each separate function.

**2.0.3** With certain obvious exceptions, symbols may be rotated or reversed without altering their meaning.

**2.0.4** The line width used does not affect the meaning of the symbol.

**2.0.5** The symbols may be drawn to any suitable size. The size may be varied on any given drawing for emphasis or clarity.

**2.0.6** Arrows are used within symbol envelopes to show the directions of flow through a component as used in the applications represented. Double-ended arrows are used to indicate reversing flow.

**2.0.7** Each symbol is drawn to show normal, at-rest, or neutral conditions of component unless multiple diagrams are furnished showing various phases of circuit operation. An actuator reversing flow.

**2.0.8** External ports are located where flow lines connect to basic symbol, except where component enclosure symbol is used. External ports are located at intersections of flow lines and component enclosure symbol when enclosure is used.

**2.0.9** The words 'Hydraulic' or 'Pneumatic' may be added to the descriptions to distinguish between the two systems or between one of them and other technical fields, for example, hydraulic pump, hydraulic cylinders, hydraulic accumulators, pneumatic motors, pneumatic valve, etc.

No.	Description	Application	Symbol
2.1.1	Line :		
2.1.1.1	-continuous	Flow lines	
2.1.1.2	-long dashes		
2.1.1.3	-short dashes		
2.1.1.4	-double	Mechanical connections (shaft, levers, piston - rods)	
2.1.1.5	-long chain thin (optional use)	Enclosure for several components assembled in one unit (see 5.5.8)	
2.1.2	Circle		
2.1.2.1		As a rule, energy conversion units (pump, compressor, motor)	
2.1.2.2		Measuring instruments	
2.1.2.3		Non-return valve, rotary connection, etc.	
2.1.2.4		Mechanical link, roller, etc.	
2.1.2.5	Semi circle	Oscillator	
2.1.3	Square, rectangular	As a rule, control valves (valve) except for non-return valves	
2.1.4	Diamond	Conditioning apparatus (filter, separator, lubricator, heat exchanger)	
2.1.5	Miscellaneous symbols		
2.1.5.1		Flow line connection	
2.1.5.2		Spring	
2.1.5.3		Restriction :	
2.1.5.3.1		-affected by viscosity	
2.1.5.3.2		-unaffected by viscosity	
2.1.5.4		weight	

### **GRAPHICAL SYMBOLS FOR FLUID POWER SYSTEMS**

(page 2, clause 2.1.2.5, under column 'Application' ) – Substitute 'semi-rotary actuator/oscillator' for 'oscillator'.

(page 7, clause 3.7, under column 'Symbol' ) – Delete the symbol for 'hydraulic to pneumatic'.





(page 9, clause 4.2.27, under column ‘Symbol’ ) – Substitute the following for the existing figure : (page 10, clause 4.2.3.5, under

## 2.2 Functional Symbol :-

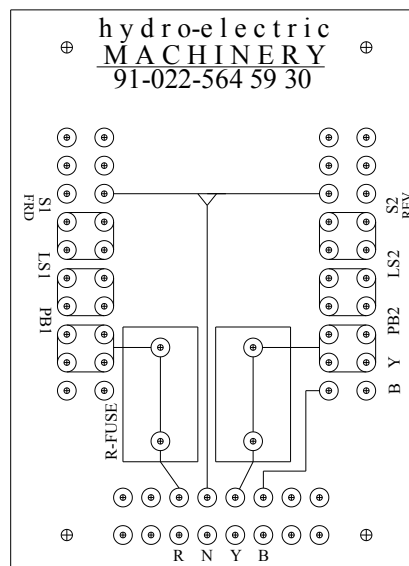

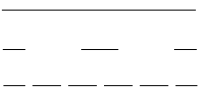
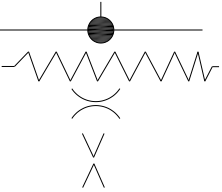
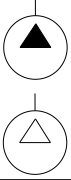
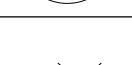

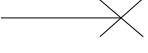
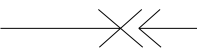

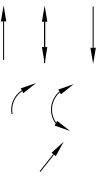

No.	Description	Application	Symbol
2.2.1	Triangle :	The direction of flow and the nature of the fluid	
2.2.1.1	-solid	Hydraulic flow	
2.2.1.2	-in outline only	Pneumatic flow or exhaust to atmosphere	
2.2.2	Arrow	Indication of :	
2.2.2.1		-direction	
2.2.2.2		-direction of rotation	
2.2.2.3		-paths and direction of flow through valves	
		Flow regulating apparatus as in 4.4 both representations with or without a tail to the end of the arrow are used without distinction	
		As a general rule the line perpendicular to the head of the arrow indicates that when the arrow moves the interior path always remains connected to the corresponding exterior path	
2.2.3	Sloping arrow	Indication of the possibility of a regulation or of a progressive variability	

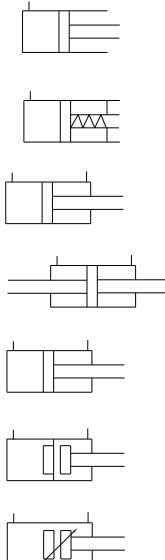
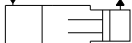

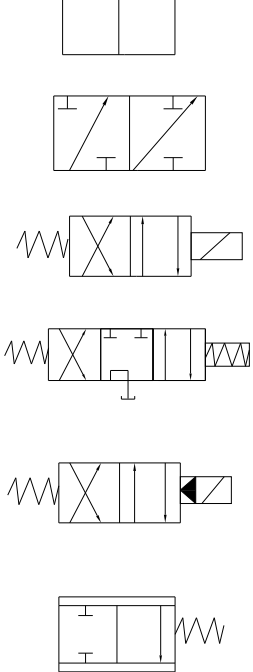

## 2.3 Energy Symbol :-



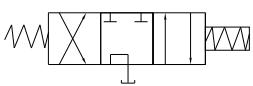
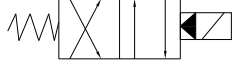
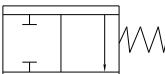

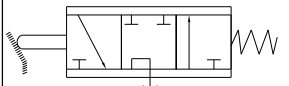
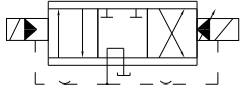

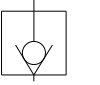
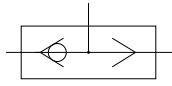
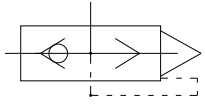
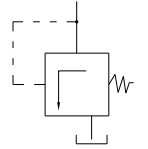
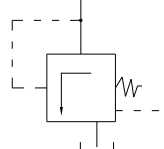
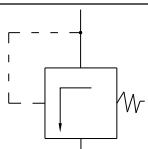
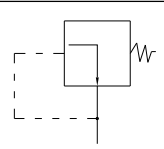
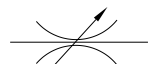
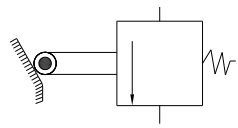

No.	Description	Symbol
1	Flow Lines	
2	Miscellaneous symbols	
3	Pressure Source	
3.1	-Hydraulic	
3.2	-Pneumatic	
4	Electric Motor	
5	Heat Engine	
6	Flexible hose, usually connected moving parts	
7	Power take-off	
7.1	-plugged	
7.2	-with take off line	
8	Triangle	
8.1	-direction of hydraulic flow in one direction.	
8.2	-direction of hydraulic flow in both directions.	
8.3	-direction of pneumatic flow or exhaust to atmosphere	
9	Arrow	
9.1	-indication of direction	
9.2	-indication of direction of rotation	
9.3	-indication of the possibility of a regulation or of a progressive variability	

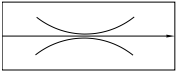
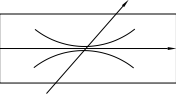
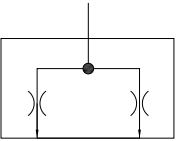
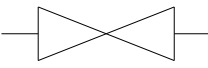

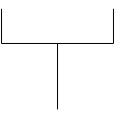

<p>10 Pump and compressure</p> <p>10.1 -fixed capacity hydraulic pump with one direction of flow (a)</p> <p>10.2 -fixed capacity hydraulic pump with two direction of flow (b)</p> <p>10.3 -variable capacity hydraulic pump with one direction of flow (a) -variable capacity hydraulic pump with one direction of flow (b)</p> <p>10.4 -fixed capacity compressure (always one direction of flow)</p> <p>10.5 -vaccum pump</p>	
<p>11 Motors</p> <p>11.1 -fixed capacity hydraulic motors with one direction of flow (a)</p> <p>11.2 -fixed capacity hydraulic motors with two direction of flow (b)</p> <p>11.3 -variable capacity hydraulic motors with one direction of flow (a)</p> <p>11.4 -variable capacity hydraulic motors with two direction of flow (b)</p> <p>11.5 -fixed capacity pneumatic motor with one direction of flow</p> <p>11.6 -fixed capacity pneumatic motor with two direction of flow</p> <p>11.7 -variable capacity pneumatic motor with one direction of flow</p> <p>11.8 -variable capacity pneumatic motor with two direction of flow</p> <p>11.9 -hydraulic oscilating motor</p> <p>11.10 -pneumatic oscaling motor</p>	

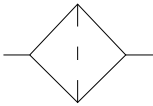
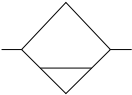
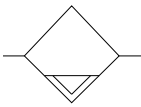
12	Cylinders	
13	Hydraulic pressure intensifier	
14	Variable speed drive unit (torque converter)	
14.1	-with variable control of pump	
14.2	-with variable control of both pump and motor	
15	Control valve	
15.1	-two position valve (No. of square is equal to the no. of position)	
15.2	-two position valve with port positions shown	
15.3	-direction control valve, four way, two position with manual operation and spring centered.	
15.4	-direction control valve, four way, three position with electromagnetic control and return and return by spring.	
15.5	-direction control valve, four way two position combined with solenoid operated pilot valve against a return spring.	
15.6	tracer valve with two parts (one throttling orifice)	

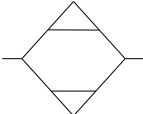
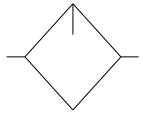
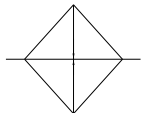
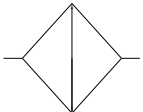
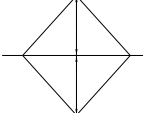
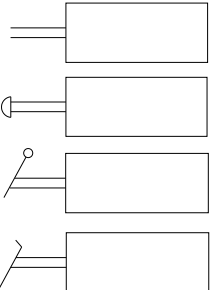
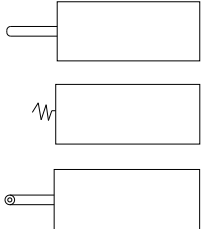
15.7	-tracer valve with three ports (two throttling orifice) plunger against a return spring	
15.8	-Two stage electrohydraulic servo valve, with hydraulic feed back and indirect pilot operation.	
16	Non-return valve	
16.1	-free (opens if the inlet pressure is greater than the outlet pressure plus the spring pressure)	
16.2	-spring loaded opens if the inlet pressure is greater than the outlet pressure plus the spring pressure)	
16.3	-pilot controlled to prevent closing of the valve (a)	
16.4	-pilot controlled to prevent opening of the valve (b)	
17	Shuttle valve	
18	Rapid exhaust valve	
19	Pressure relief valve (safety valve)	
19.1	-with remote pilot control	
20	Sequence valve	
21	Pressure regulator or reducing valve	
22	Flow control valve	
22.1	-throttling valve	
22.1.1	-with mechanical control against a return spring (braking valve)	

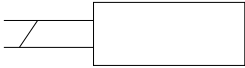
22.2	-flow control valve with fixed output	
22.3	-flow control valve with variable output	
23	Flow dividing valve	
24	Shut-off valve	
25	Silencer	
26	Reservoirs	
26.1	-with inlet pipe above fluid level	
26.2	-with inlet pipe below fluid level	
26.3	-with a header line	
27	Accumulators	
28	Filter or strainer	
29	Water trap	
29.1	-with manual control	
29.2	-automatically drained	

30 Air dryer	
31 Lubricator	
32 Heater	
33 Cooler	
34 Temperature controller	
35 Manual controller 35.1 -general (without indication of control type) 35.2 -by push button 35.3 -by lever 35.4 -by pedal	
36 Mechanical control 36.1 -by plunger or tracer 36.2 -by spring 36.3 -by roller	

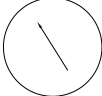
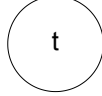
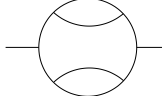
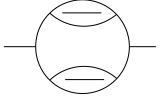
36.4 -by roller, opening in one direction only	
37 Electrical control 37.1 -by solenoid 37.2 -electric motor	 
38 Control by application or release of pressure 38.1 -by application of pressure (direct acting) 38.2 -indirect control, pilot actuated by application of pressure 38.3 -indirect control, pilot actuated by release of pressure	  
39 Pressure Guage	
40 Thermometer	
41 Flow meter	
42 Intergrating flow meter	
43 Pressure switch (electrically operated)	